SMART WIRING SYSTEM (SWS)

SMART WIRING SYSTEM (SWS)

CONTENTS

GENERAL INFORMATION	54B-2	TROUBLESHOOTING	54B-6
SPECIAL TOOLS	54B-5		



GENERAL INFORMATION

COMMUNICATION LINE

Data lines for multiplex communication are connected between the front-ECU, ETACS-ECU, column switch assembly, multi-center display, power window main switch, and power window motors as illustrated below.

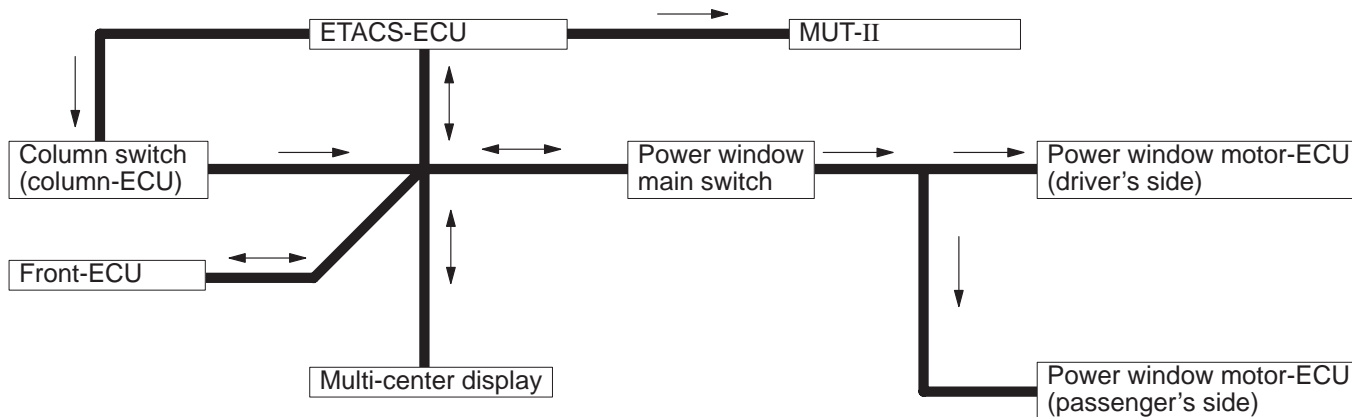

→ : Uni-directional communication line
 ↔ : Bi-directional communication line

OPERATION

BUZZER

Light Reminder Warning Function

When the driver's door is opened (driver's door switch ON) with light switch in the TAIL or HEAD position, the buzzer will sound continuously to remind the driver that the lights (taillights or headlights) are ON.

CENTRAL DOOR LOCKING SYSTEM

Central Door Locking System Operation

If a door is locked or unlocked by using any one of the key cylinders (driver's door, passenger's door or back door), all of the doors are locked or unlocked. In addition, all doors can be locked and unlocked by using the driver's door lock knob.

Multi-center Display Buzzer Function

If there is a request from the multi-center display to make the buzzer sound, the ETACS-ECU causes the buzzer to sound.

Forgotten Key Prevention Function

This function automatically release the door lock if the inside door lock knob is placed in the lock position with the door opened while the key is still in the ignition switch, thereby preventing the key from being left behind locked door.

POWER WINDOWS

Power Windows Operation

A signal line dedicated for transmission of multiplex communication data is connected between the power window main switches and the power window motor-ECU.

Communication is uni-directional. The power window main switches have a transmitting circuit only, whereas the power window sub switches have a receiving circuit only.

KEYLESS ENTRY SYSTEM

If the transmitter LOCK or UNLOCK switch is pressed while the ignition key is removed and all of the doors are closed, the doors can be locked or unlocked. If the doors are closed, the hazard warning lamps, the room lamp and the horn will operate due to answerback function. Because of the answerback function, the hazard warning lamps

WINDSHIELD WIPER AND WASHER

Windshield Low-speed (and High-speed) Wiper Operation

- If the windshield low-speed wiper switch is turned to the ON position with the ignition switch at the ACC or ON position, the column switch sends a low-speed wiper ON and high-speed wiper OFF signals to the front-ECU. This turns the wiper signal on and the wiper speed switching relay off (low-speed), causing the wipers to operate at low-speed.
- If the windshield high-speed wiper switch is turned to the ON position, the column switch sends a low-speed wiper OFF and high-speed wiper ON signals to the front-ECU. This turns both the wiper signal and the wiper speed switching relay on (high-speed), causing the wipers to operate at high-speed.

Windshield Intermittent Wiper Operation

The ETACS-ECU calculates the wiper operation interval according to the voltage signal sent from the column switch. (For vehicles without variable intermittent wiper, the intermittent interval is fixed at 4 seconds.) Then the ETACS-ECU sends a signal to the front-ECU. The front-ECU determines the wiper operation interval and turns on the wiper signal relay. This causes the wiper auto stop relay to turn on. Then the wiper auto stop relay will turn off after the wipers reach the park position. This causes the wiper signal relay and then the wipers to turn off.

If the wiper signal relay remains off for the wiper operation interval, the relay turns on again, causing the wipers to operate in intermittent mode.

Power Window Timer Function

With the ignition switch in the ON position, the power window relay and power window switch receipt permission are turned ON [the power window switch receipt permission signal remains ON for 30 seconds after the ignition switch is turned LOCK (OFF)], enabling opening and closing of the windows. The power window relay goes ON for additional 30 seconds. If the driver's door is subsequently closed during this period, the receipt permission signal goes OFF. The power window relay goes OFF 10 seconds after the receipt permission signal goes OFF.

flash twice, and the room lamp flashes twice when the doors are locked. Meanwhile, when the doors are unlocked, the hazard warning lamps flash and the room lamp illuminate for 15 seconds. The hazard answerback functions can be cancelled by using the MUT-II.

Windshield Mist Wiper Operation

- If the windshield mist wiper switch of the column switch is turned to the ON position with the ignition switch at ACC or ON position, the mist wiper high-speed operation signal is sent to the front-ECU. This signal turns on the wiper speed switching relay, causing the wipers to work at high-speed while the mist switch is on.
- While the windshield mist wiper switch remains turned on when the intermittent mode is still working, the wipers work as the mist wiper. However, the wipers return to the intermittent mode again when the wiper auto stop signal turns on after the mist wiper switch is turned off.

Windshield Washer Operation

If the windshield washer switch of the column switch is turned to the ON position with the ignition switch at ACC or ON position, the windshield washer ON signal is sent to the front-ECU, causing the windshield wiper signal to turn on after 0.3 seconds. After the windshield washer switch signal turns off, the windshield wiper signal turns off in three seconds.

If the windshield wiper switch is turned to the ON position while the windshield wiper is at intermittent mode, the windshield washer works for that period when the windshield washer switch remains on. Then the wipers return to the intermittent mode.

REAR WIPER AND WASHER

Rear Wiper Operation

If the rear wiper switch is turned to the ON position with the ignition switch at ACC or ON position, the ETACS-ECU cause the rear wiper to operate continuously two times then intermittently at eight-second intervals.

If the shift lever <M/T> selector lever <A/T> is moved to the R position when the rear wiper switch is turned to the ON position and the ignition switch at ACC or ON position, back-up lamp switch <M/T> or inhibitor switch R <A/T> turns ON. One second later, the ETACS-ECU causes the rear wiper to operate two times continuously to ensure good rearward visibility. The ETACS-ECU then causes the rear wiper to again operate intermittently at eight-second intervals.

HEADLAMP WASHER

If the headlamp washer switch of the column switch assembly is turned to the ON position with the

HEADLAMP

Headlamp Auto-cut Function

If the ignition switch is turned to LOCK (OFF) or ACC position, when the headlamps are on, the headlamps will be switched off in three minutes. If the driver's door is opened within that three-minute period, the headlamps will be switched off automatically. This prevents the battery from discharged.

In addition, if the headlamps are turned on when the ignition switch is at LOCK (OFF) or ACC position, the headlamps will not be switched off.

FLASHER TIMER

Turn-signal Lamp

When the ignition switch is turned to ON position and turn-signal lamp switch is placed in the ON position for right or left turn signaling, the system generates turn-signal lamp drive signals (flashing signals).

The system also notifies of a blown turn-signal lamp bulb by shortening the flashing intervals of the corresponding indicator lamp.

FRONT FOG LAMP

The front fog lamp switch becomes active only when the tail lamps are on. Therefore, if the tail lamps are turned off, the fog lamps will also be switched

REAR FOG LAMP

The rear fog lamp switch becomes active only when the headlamps or front fog lamps* are on. Therefore, if the headlamps and front fog lamps* are turned off, the rear fog lamps will also be switched off. Whenever the headlamps or front fog lamps* are

Rear Washer Operation

If the rear washer switch is turned to the ON position with the ignition switch at ACC or ON position, the rear washer ON signal is sent to the ETACS-ECU, causing the rear wiper signal to turn on after 0.3 seconds. After the rear washer switch signal turns off, the rear wiper signal turns off in three seconds. If the rear wiper switch is turned to the ON position while the rear wiper is at intermittent mode, the rear washer works for that period when the washer switch remains on. Then the rear wipers return to the intermittent mode.

ignition switch in the ACC or ON position, the front-ECU turns on the headlamp washer relay.

Headlamp Dimmer Switch Auto-reset Function

This function allows the dimmer switch to be reset to the low-beam position whenever the headlamp switch is turned ON.

Daytime Running Lamp (DRL) Function

If the ignition switch is turned to ON when the headlamps and tail lamps are off, the headlamps (low-beam) and tail lamps turn on.

Hazard Warning Lamp

The system detects a change from ON to OFF of the hazard lamp input signal and activates the hazard lamps if they are not in operation or deactivates the lamps if they are operating (reversal of state between activation and deactivation).

off. Whenever the tail lamps are turned on at the next time, the front fog lamps will always be off regardless of the switch positions.

turned on at the next time, the rear fog lamps will always be off regardless of the switch positions.

NOTE

*: In vehicles without front fog lamps, these conditions apply to the headlamps only.

ROOM LAMP

With the room lamp switch in the DOOR position, the ETACS-ECU controls the room lamp operation as follows:

- When a door is opened from outside or inside [with the ignition switch turned to LOCK (OFF) position]:
When a door is opened, the ETACS-ECU causes the room lamp to be illuminated at the 100% intensity. When the door is closed, it dims out the room lamp to 65% intensity and approx. 30 seconds later, turns out the lamp completely. During this period (timer controlled period), the room lamp does out if the ignition switch is turned to ON position or the doors are locked.
- When a door is opened or closed with the ignition switch in the ON position:
The room lamp illuminates at 100% intensity when a door is opened and turned out when it is closed.
- When no door is opened and the ignition key is removed:

When the ignition key is removed with all the doors closed, the room lamp is illuminated at an intensity of 65% and turned out approx. 30 seconds later. During that time (timer-controlled period), the room lamp does out if the ignition key is inserted and turned to ON position or the door locking system is activated.

- Room lamp's answerback operation in response to door lock control by keyless entry system:

To allow the driver to ascertain the result of the door locking/unlocking control action by the use of the keyless entry system, the ETACS-ECU causes the room lamp to blink twice when the doors are locked through the system and to illuminate for approx. 15 seconds when the doors are locked.

The room lamp's answerback operation in response to a keyless entry system control action is accompanied by operation of the hazard warning lamps.

SPECIAL TOOLS

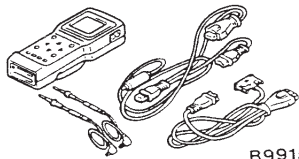
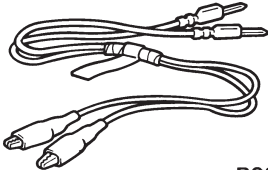
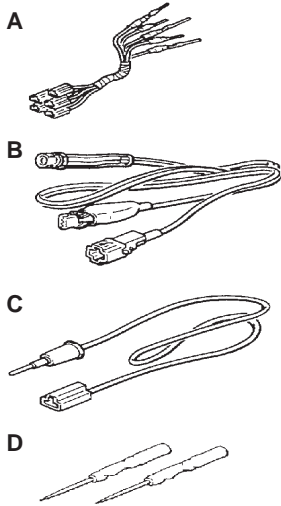
Tool	Number	Name	Use
 <p>B991502</p>	MB991502	MUT-II sub assembly	Checking of the SWS (Diagnosis code display and input check with the MUT-II)
 <p>B991529</p>	MB991529	Diagnosis code check harness	Simple diagnosis
 <p>A B C D</p> <p>C991223</p>	MB991223 A: MB991219 B: MB991220 C: MB991221 D: MB991222	Harness set A: Test harness B: LED harness C: LED harness adapter D: Probe	Measurement of terminal voltage at ECUs A: Connector pin contact pressure inspection B: Power circuit inspection C: Power circuit inspection D: Commercial tester connection

TROUBLESHOOTING

STANDARD FLOW OF DIAGNOSTIC TROUBLESHOOTING

Refer to GROUP 00 – How to Use Troubleshooting/Inspection Service Points.

DIAGNOSTIC FUNCTION

DIAGNOSIS CODES CHECK

Use the MUT-II to check a diagnosis code.

(Refer to GROUP 00 – How to Use Troubleshooting/Inspection Service Points.)

NOTE

Connect the MUT-II to the 16-pin diagnosis connector (black).

INPUT SIGNAL CHECK

1. Use the MUT-II to check a input signal.
(Refer to GROUP 00 – How to Use Troubleshooting/Inspection Service Points.)
2. In this condition, the following input switches can be checked.
3. If an abnormality is found during the input signal check, carry out troubleshooting while referring to the Trouble Symptom Check page.

Input Signal Check Function

Input signal	Buzzer operation condition
Ignition switch (ACC)	Turned from LOCK (OFF) to ACC
Ignition switch (IG1)	Turned from ACC to ON
Key reminder switch	Ignition key removed from ignition key cylinder (from inserted position)
Hazard warning lamp switch	Turned from OFF to ON
Front fog lamp switch <vehicles with front fog lamp>	
Rear fog lamp switch	
Back-up lamp switch <M/T>	Shift lever moved to R position
Inhibitor switch (reverse) <A/T>	Selector lever moved to R position
Rear wiper motor auto-stop signal	Rear wiper begins to operate (The input signal is sent before the rear wiper begins to operate)
Driver's door switch	Driver's door opened from closed condition
Door switches	All doors closed to any door opened
Passenger's door key cylinder switch <vehicles with central door locking system>	Passenger's door locked or unlocked using ignition key
Back door key cylinder switch <vehicles with central door locking system>	Back door locked or unlocked using ignition key
Driver's door lock actuator switch <vehicles with central door locking system>	Driver's door lock knob moved from lock position to unlock position or vice versa

Input signal		Buzzer operation condition
Column switch	Tail lamp switch	Turned the lighting switch from OFF to tail lamp position
	Headlamp switch	Turn the lighting switch from tail lamp position to headlamp position
	Dimmer switch	Turned from OFF to ON
	Passing switch	
	Turn-signal lamp switch	
	Windshield mist wiper switch	
	Windshield intermittent wiper switch	
	Windshield low-speed wiper switch	
	Windshield high-speed wiper switch	
	Windshield intermittent wiper interval adjusting knob <vehicles with variable windshield intermittent wiper>	Rotate the windshield intermittent wiper interval adjusting knob from FAST to SLOW when the ignition switch is at ON position (The ETACS-ECU sends a signal around the medium knob position)
	Windshield washer switch	Turned from OFF to ON
	Rear wiper switch	
	Rear washer switch	
Headlamp washer switch <vehicles with headlamp washer>		
Power window main switch	Any switch <vehicles with power window>	
Transmitter	Any switch <vehicles with keyless entry system>	
Multi-center display	Any switch <vehicles with multi-center display>	

DIAGNOSIS CODE CHART

Code No.	Diagnosis item	Reference page
11	Failure concerning the ETACS-ECU	54B-8
12	Failure concerning the column switch or improper connecting with the ETACS-ECU	54B-8
13	Failure concerning the front-ECU	54B-9
21	Short circuit in communication line	54B-10

DIAGNOSIS CODE INSPECTION PROCEDURES

Code No.11 Failure concerning the ETACS-ECU	Probable cause
The ETACS-ECU monitors its own communication data, and sends a diagnosis code when an error takes place consecutive fifteen times in 0.6 second. The diagnosis code will be erased when the ETACS-ECU determines that its own communication data is sent consecutive 15 times in 0.6 second.	<ul style="list-style-type: none"> Malfunction of ETACS-ECU

Replace the ETACS-ECU.

Code No.12 Failure concerning the column switch or improper connection with the ETACS-ECU	Probable cause
This diagnosis code is displayed when the column switch sends a signal regardless of the transmission request signal from the ETACS-ECU (three times or more in one second). The diagnosis code is erased when the column switch continues to send a signal according to the transmission request signal from the ETACS-ECU for one second.	<ul style="list-style-type: none"> Malfunction of column switch Malfunction of ETACS-ECU Malfunction of wiring harness or connector

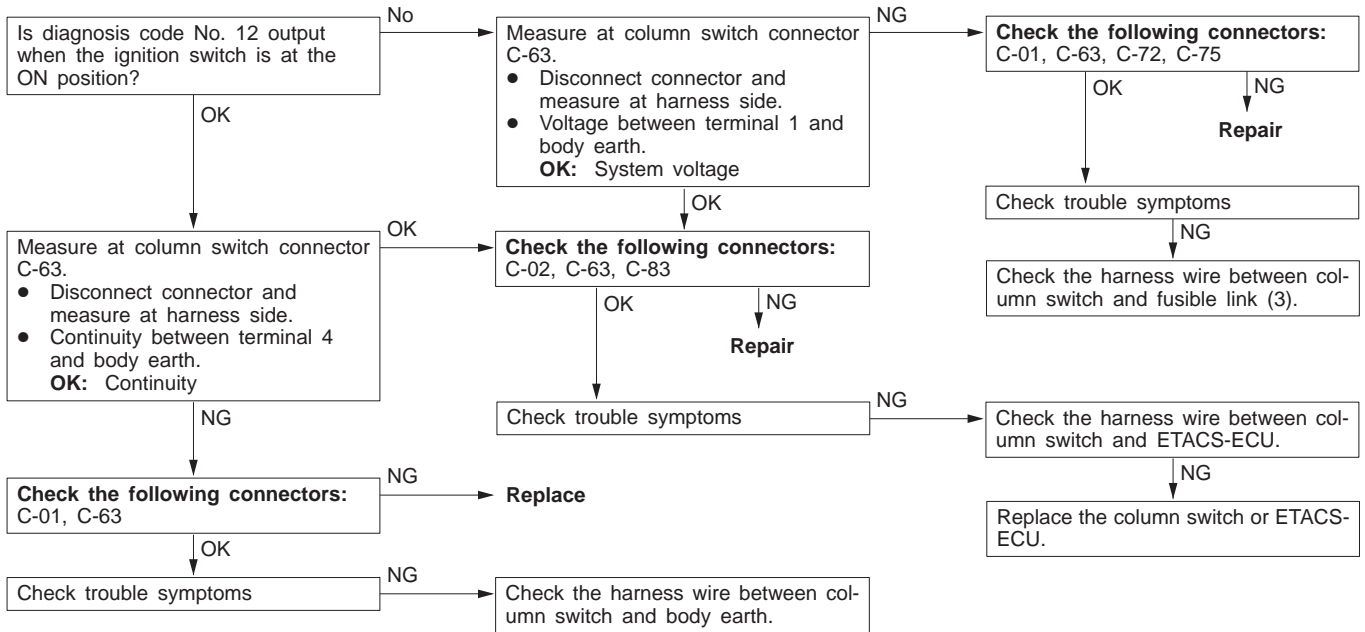

Code No.13 Failure concerning the front-ECU	Probable cause
This diagnosis code is displayed when the signals that the front-ECU sends to the ETACS-ECU are errors consecutive fifteen times in 0.6 second. The diagnosis code will be erased when the front-ECU sends normal signals to the ETACS-ECU consecutive 15 times in 0.6 second.	<ul style="list-style-type: none"> ● Malfunction of front-ECU ● Malfunction of ETACS-ECU ● Malfunction of wiring harness or connector

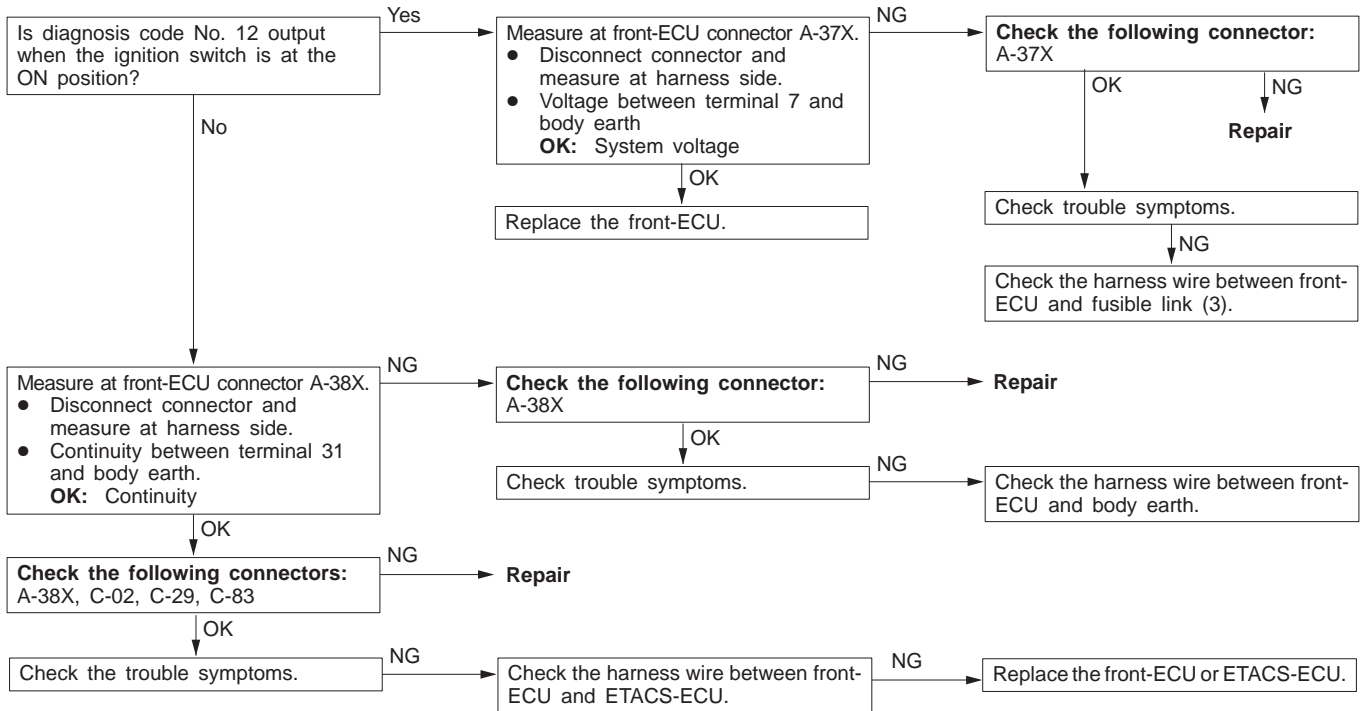

Code No.21 Short circuit in communication lines	Probable cause
<p>This diagnosis code is displayed when the SWS communication line voltage reaches the LO level for 0.3 second. The diagnosis code is erased when voltage in the ETACS-ECU data line reaches the HI level for 0.3 second, or the ETACS-ECU receives a normal signal from other ECUs or switches. While this code is displayed, other codes are not displayed.</p>	<ul style="list-style-type: none"> ● Malfunction of column switch ● Malfunction of front-ECU ● Malfunction of power window main switch <vehicles with front power window> ● Malfunction of multi center display <vehicles with multi center display> ● Malfunction of ETACS-ECU ● Malfunction of wiring harness or connector

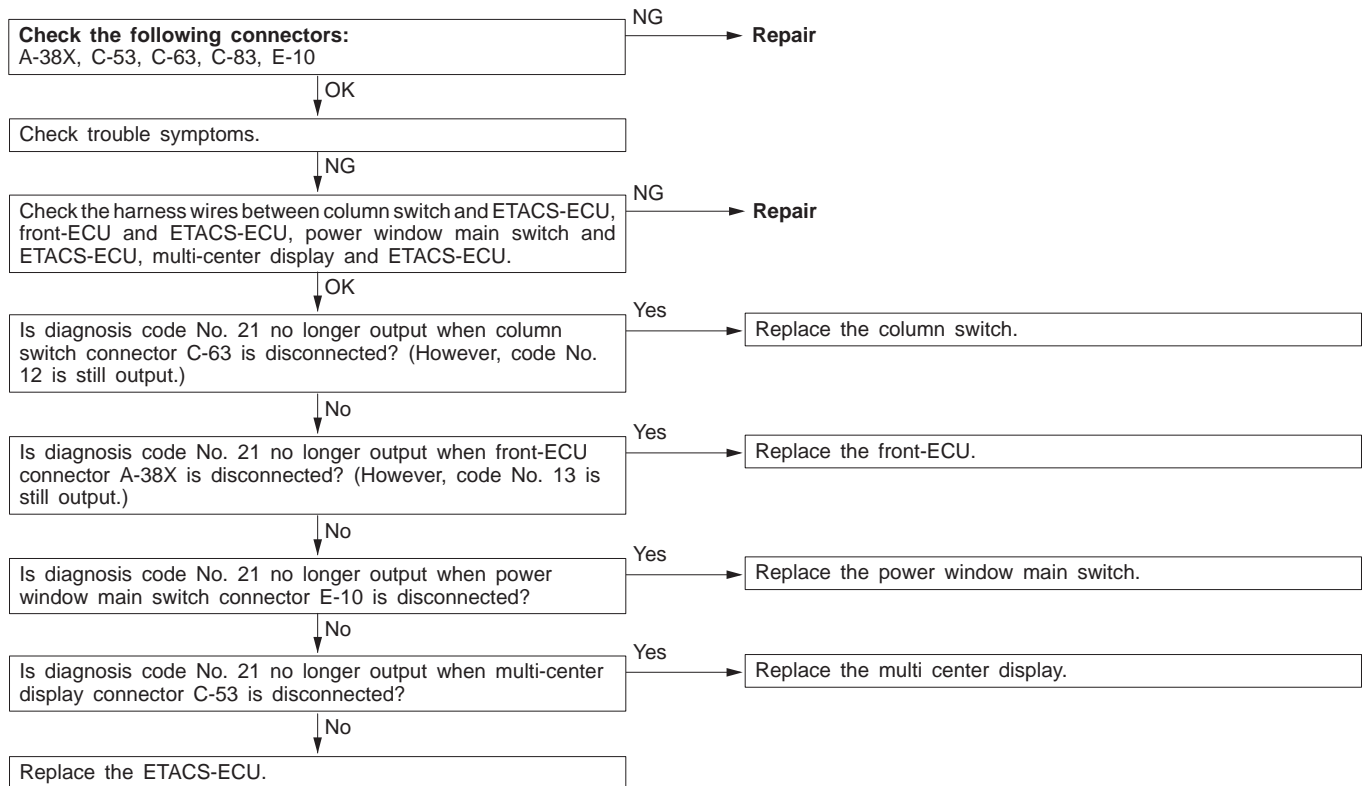

TROUBLE SYMPTOM CHART

Trouble symptom		Inspection procedure	Reference page
Communication with the MUT-II is impossible.		A-1	54B-14
Buzzer	Light reminder warning function does not work normally.	B-1	54B-15
	Multi-center display alarm function does not work normally.	B-2	54B-15
Central door locking system	Central door locking system does not work normally.	C-1	54B-16
	Some doors do not lock or unlock.	C-2	54B-16
	All the doors do not lock or unlock with just the driver's door lock key cylinder key operation or driver's inside lock knob operation.	C-3	54B-17
	All the doors do not lock or unlock with just the passenger's or back door lock key cylinder key operation.	C-4	54B-17
	Forgotten key prevention function does not work.	C-5	54B-17
Power window	Power window do not work at all.	D-1	54B-18
	Power window main switch can not operate driver's window.	D-2	54B-18
	Power window sub switch can not operate passenger's window.	D-3	54B-19
	Power window main switch can not operate passenger's window.	D-4	54B-20
	Power window timer function does not work normally.	D-5	54B-20
	When the glass is raised, it then lowers automatically.	D-6	54B-21
	The glass is not lowered when something is jammed in the window.	D-7	54B-21
	When the glass is fully raised, it then lowers automatically.	D-8	54B-21
Keyless entry system	Keyless entry system does not operate.	E-1	54B-22
	The room lamp and hazard warning lamps do not operate through the answerback function.	E-2	54B-22
	The encrypted code cannot be registered.	E-3	54B-22
Windshield wiper and washer	Windshield wiper does not operate.	F-1	54B-23
	Any of the windshield wiper switch positions is defective.	F-2	54B-24
	Windshield wiper does not stop at the predetermined park position.	F-3	54B-24
	Windshield intermittent wiper interval cannot be adjusted.	F-4	54B-25
	Windshield washer does not work.	F-5	54B-25

Trouble symptom		Inspection procedure	Reference page
Rear wiper and washer	Rear wiper does not work at all.	G-1	54B-26
	Rear wiper does not stop at the predetermined park position.	G-2	54B-26
	When the shift lever <M/T> or selector lever <A/T> is moved to R position during the rear wiper operation, the rear wiper does not operate at the continuous mode.	G-3	54B-27
	Rear washer does not work.	G-4	54B-27
Headlamp washer	Headlamp washer does not work.	H-1	54B-28
Headlamp, tail lamp	Tail lamp do not illuminate.	I-1	54B-29
	Headlamps (low-beam) do no illuminate.	I-2	54B-29
	Headlamps (high-beam) do no illuminate.	I-3	54B-30
	Headlamps do not illuminate when the passing switch is operated.	I-4	54B-30
	The headlamp auto-cut function does not work normally.	I-5	54B-31
	Headlamp dimmer switch auto-reset function does not work normally.	I-6	54B-31
	Daytime running lamp (DRL) function does not work.	I-7	54B-31
Flasher timer	Turn-signal lamp do not flash when the turn-signal lamp switch is turned on.	J-1	54B-32
	Hazard warning lamps do not flash when the hazard warning lamp switch is turned on.	J-2	54B-33
Front fog lamp	Front fog lamps do not illuminate when the front fog lamp switch is turned on.	K-1	54B-34
	Front fog lamp do not go out when the tail lamps are turned off while the fog lamps are on.	K-2	54B-34
Rear fog lamp	Rear fog lamp do not illuminate when the rear fog lamp switch is turned on.	L-1	54B-35
	Rear fog lamp do not out when the headlamps and front fog lamps <vehicles with front fog lamp> are turned off while the fog lamp is on.	L-2	54B-36
Room lamp	The room lamp does not illuminate.	M-1	54B-36
	The doom lamp dimming function does not work normally.	M-2	54B-37
Multi-center display	The multi-center display does not work normally.	–	GROUP 54A – Multi-center Display.

DEFECTS FOUND BY INPUT SIGNAL CHECK

If the input signal check finds a defect, follow the table below to check.

Trouble symptom		Inspection procedure	Reference page
Ignition switch (ACC) signal is not sent to the ETACS-ECU.		N-1	54B-37
Ignition switch (IG1) signal is not sent to the ETACS-ECU.		N-2	54B-38
Key reminder switch signal is not sent to the ETACS-ECU.		N-3	54B-38
Hazard warning lamp switch signal is not sent to the ETACS-ECU.		N-4	54B-39
Front fog lamp switch signal is not sent to the ETACS-ECU.		N-5	54B-39
Rear fog lamp switch signal is not sent to the ETACS-ECU.		N-6	54B-40
Back-up lamp switch signal is not sent to the ETACS-ECU. <M/T>		N-7	54B-40
Inhibitor switch (reverse) signal is not sent to the ETACS-ECU. <A/T>		N-8	54B-41
Rear wiper motor auto-stop signal is not sent to the ETACS-ECU.		N-9	54B-41
Driver's door switch signal is not sent to the ETACS-ECU.		N-10	54B-42
Door switches signal is not sent to the ETACS-ECU.			
Passenger's door lock key cylinder switch signal is not sent to the ETACS-ECU.		N-11	54B-43
Back door lock key cylinder switch signal is not sent to the ETACS-ECU.		N-12	54B-43
Driver's door lock actuator switch signal is not sent to the ETACS-ECU.		N-13	54B-44
Column switch	Tail lamp switch signal is not sent to the ETACS-ECU.	N-14	54B-45
	Headlamp switch signal is not sent to the ETACS-ECU.		
	Dimmer switch signal is not sent to the ETACS-ECU.		
	Passing switch signal is not sent to the ETACS-ECU.		
	Turn-signal lamp switch signal is not sent to the ETACS-ECU.		
	Windshield mist wiper switch signal is not sent to the ETACS-ECU.		
	Windshield intermittent wiper switch signal is not sent to the ETACS-ECU.		
	Windshield low-speed wiper switch signal is not sent to the ETACS-ECU.		
	Windshield high-speed wiper switch signal is not sent to the ETACS-ECU.		
	Windshield intermittent wiper interval adjusting knob signal is not sent to the ETACS-ECU.	N-15	54B-45
	Windshield wiper switch signal is not sent to the ETACS-ECU.	N-14	54B-45
	Rear wiper switch signal is not sent to the ETACS-ECU.		
	Rear washer switch signal is not sent to the ETACS-ECU.		
	Headlamp washer switch signal is not sent to the ETACS-ECU.		

Trouble symptom		Inspection procedure	Reference page
Power window main switch	Any switch signal is not sent to the ETACS-ECU.	N-16	54B-46
Transmitter	Any switch signal is not sent to the ETACS-ECU.	N-17	54B-46
Multi-center display	Any switch signal is not sent to the ETACS-ECU.	N-18	54B-47

INSPECTION PROCEDURE FOR TROUBLE SYMPTOMS

Inspection Procedure A-1

Communication with the MUT-II is impossible.	Probable cause
The harness wires between the ETACS-ECU power supply line or the ETACS-ECU and the diagnosis connector may be defective.	<ul style="list-style-type: none"> • Malfunction of ETACS-ECU • Malfunction of harness wire or connector

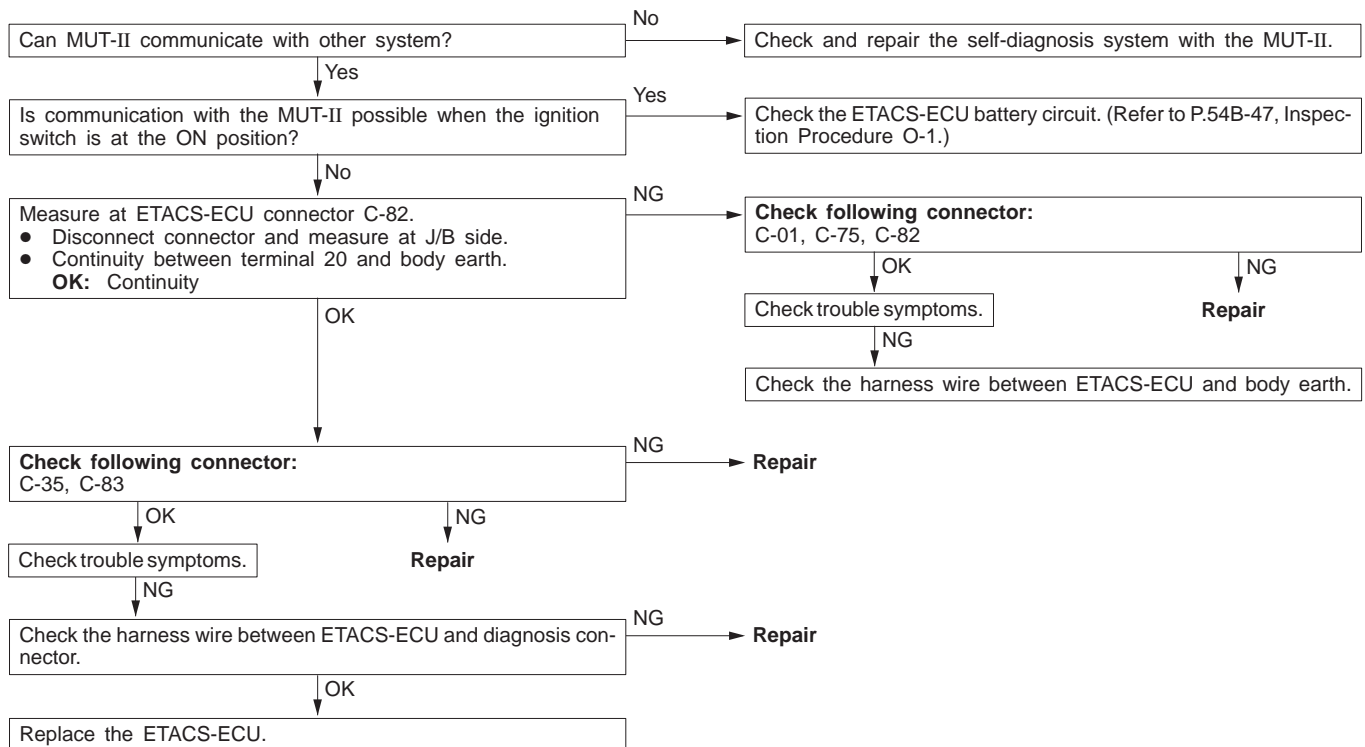

Inspection Procedure B-1

Buzzer: Light reminder warning function does not work normally.	Probable cause
<p>The ETACS-ECU operates the light reminder warning function, based on input signals from the following switched:</p> <ul style="list-style-type: none"> ● Ignition switch (IG1) ● Driver's door switch ● Tail lamp switch ● headlamp switch <p>If the function does not work normally, a defect on the relevant circuit or the ETACS-ECU may be suspected.</p>	<ul style="list-style-type: none"> ● Malfunction of driver's door switch ● Malfunction of column switch ● Malfunction of ETACS-ECU ● Malfunction of harness wire or connector

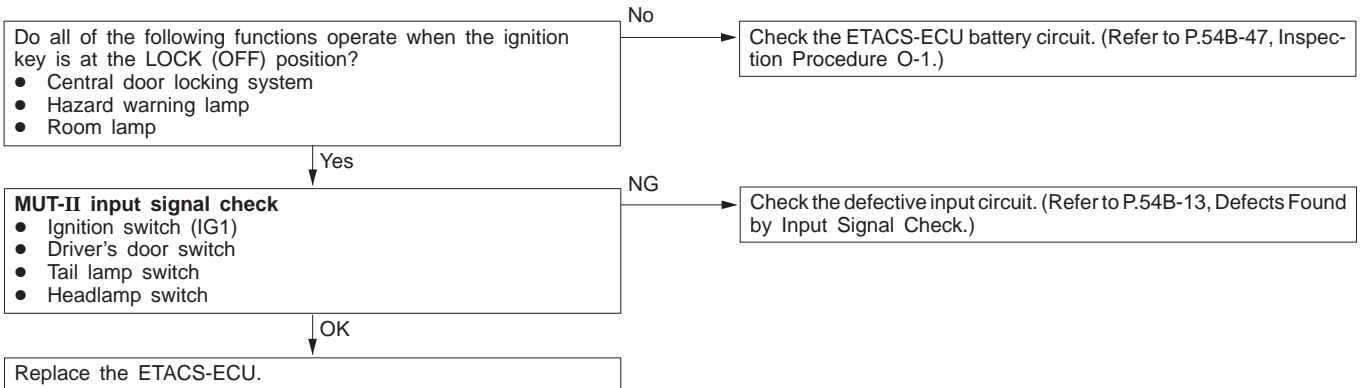

Inspection Procedure B-2

Buzzer: Multi-center display buzzer function does not work normally.	Probable cause
<p>If the multi-center display is operating normally, the cause is probably a malfunction in the harness between the multi-center display and the ETACS-ECU or in the ETACS-ECU itself.</p>	<ul style="list-style-type: none"> ● Malfunction of multi-center display ● Malfunction of ETACS-ECU ● Malfunction of harness wire or connector

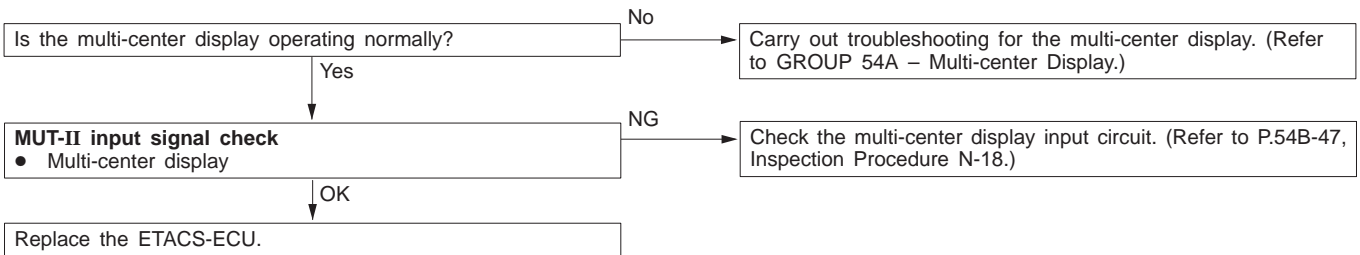

Inspection Procedure C-1

Central door locking system: Central door locking system does not work normally.	Probable cause
The power supply circuit, the circuit shared by door lock actuators, or the ETACS-ECU may be defective.	<ul style="list-style-type: none"> • Malfunction of ETACS-ECU • Malfunction of harness wire or connector

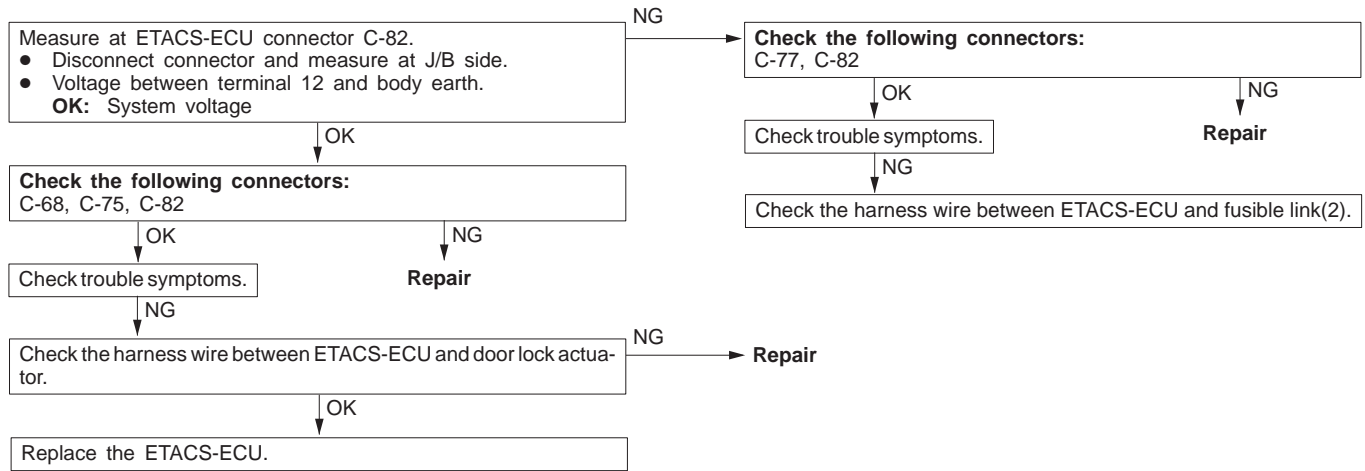

Inspection Procedure C-2

Central door locking system: Some doors do not lock or unlock.	Probable cause
The door lock actuator, or the harness wire between ETACS-ECU and the door lock actuator may be defective.	<ul style="list-style-type: none"> • Malfunction of driver's, passenger's or back door lock actuator • Malfunction of ETACS-ECU • Malfunction of harness wire or connector

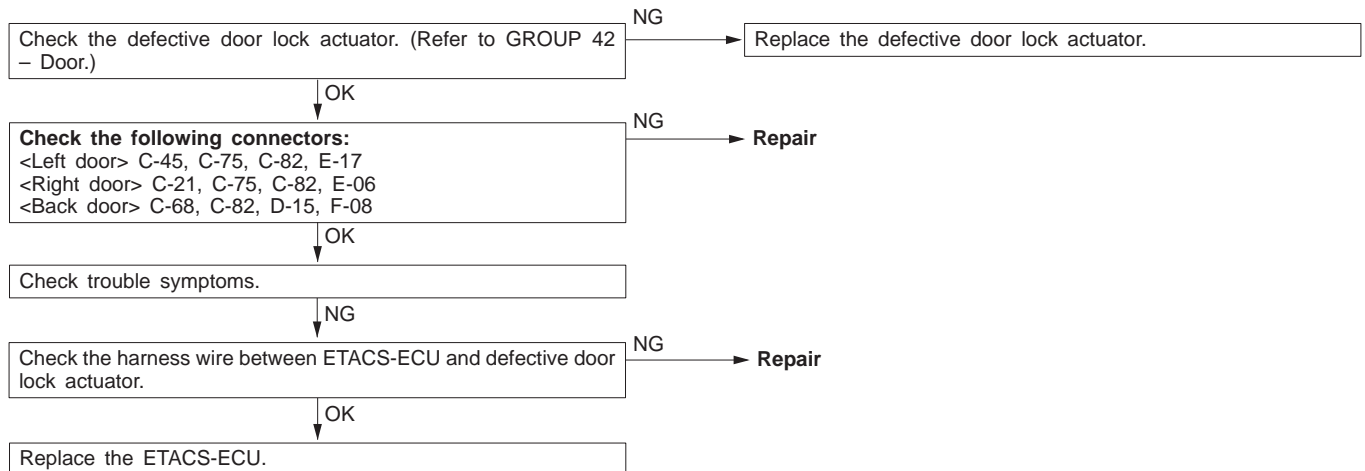

Inspection Procedure C-3

Central door locking system: All the doors do not lock or unlock with just the driver's door lock key cylinder key operation or driver's inside lock knob operation.	Probable cause
The driver's door lock actuator switch or the ETACS-ECU may be defective.	<ul style="list-style-type: none"> ● Malfunction of driver's door lock actuator ● Malfunction of ETACS-ECU ● Malfunction of harness wire or connector

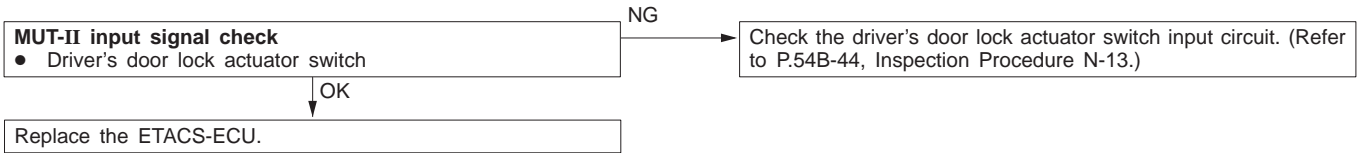

Inspection Procedure C-4

Central door locking system: All the doors do not lock or unlock with just the passenger's or back door lock key cylinder key operation.	Probable cause
The passenger's or back door lock key cylinder or the ETACS-ECU may be defective.	<ul style="list-style-type: none"> ● Malfunction of passenger's or back door lock key cylinder switch ● Malfunction of ETACS-ECU ● Malfunction of harness wire or connector

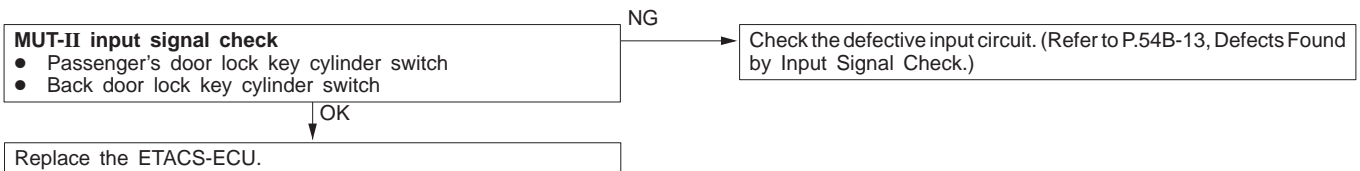

Inspection Procedure C-5

Central door locking system: Forgotten key prevention function does not work.	Probable cause
The ETACS-ECU operates the forgotten key prevention function, based on the input signals from the following switches: <ul style="list-style-type: none"> ● Key reminder switch ● Driver's door switch ● Driver's door lock actuator switch If the function does not work normally, a defect on the relevant circuit or the ETACS-ECU may be suspected.	<ul style="list-style-type: none"> ● Malfunction of key reminder switch ● Malfunction of driver's door switch ● Malfunction of driver's door lock actuator ● Malfunction of ETACS-ECU ● Malfunction of harness wire or connector

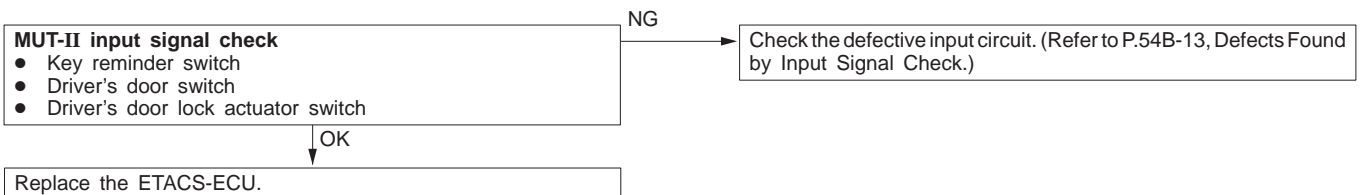

Inspection Procedure D-1

Power window: Power window do not work at all.	Probable cause
The power window relay or the ETACS-ECU may be defective.	<ul style="list-style-type: none"> ● Malfunction of power window relay ● Malfunction of ETACS-ECU ● Malfunction of harness wire or connector

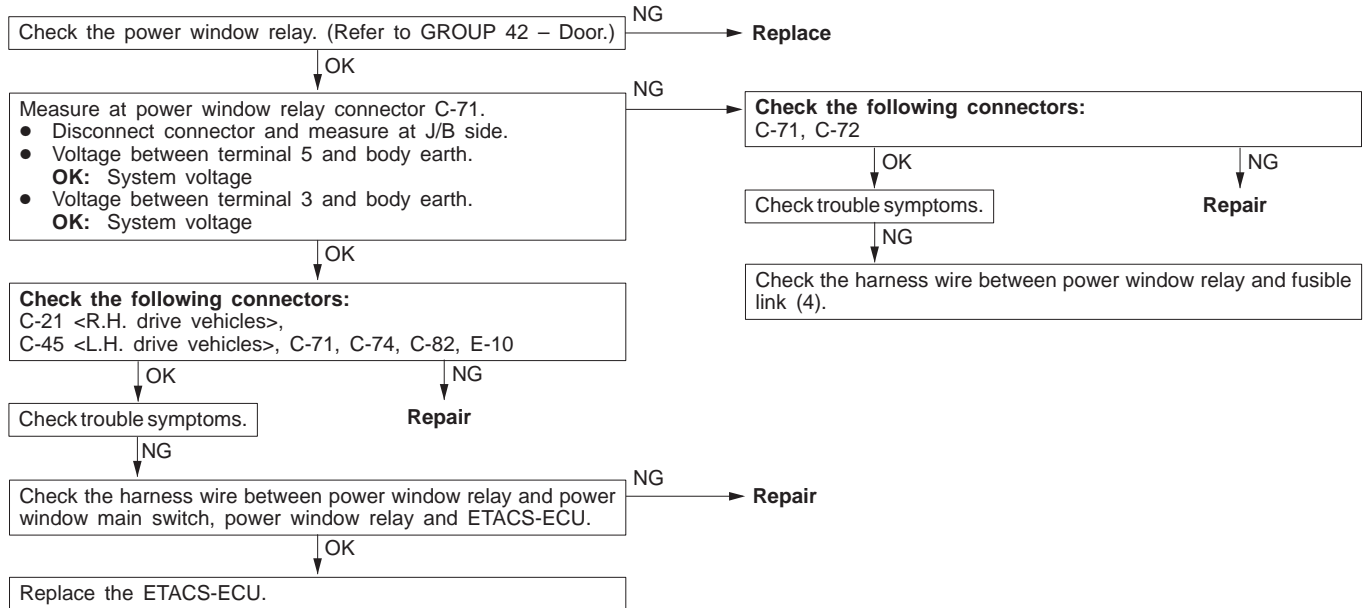

Inspection Procedure D-2

Power window: Power window main switch can not operate drive's window.	Probable cause
The cause is probably a malfunction of the power window main switch or driver's side power window motor, or an abnormality in the power supply circuit.	<ul style="list-style-type: none"> ● Malfunction of power window main switch ● Malfunction of driver's power window motor ● Malfunction of harness wire or connector

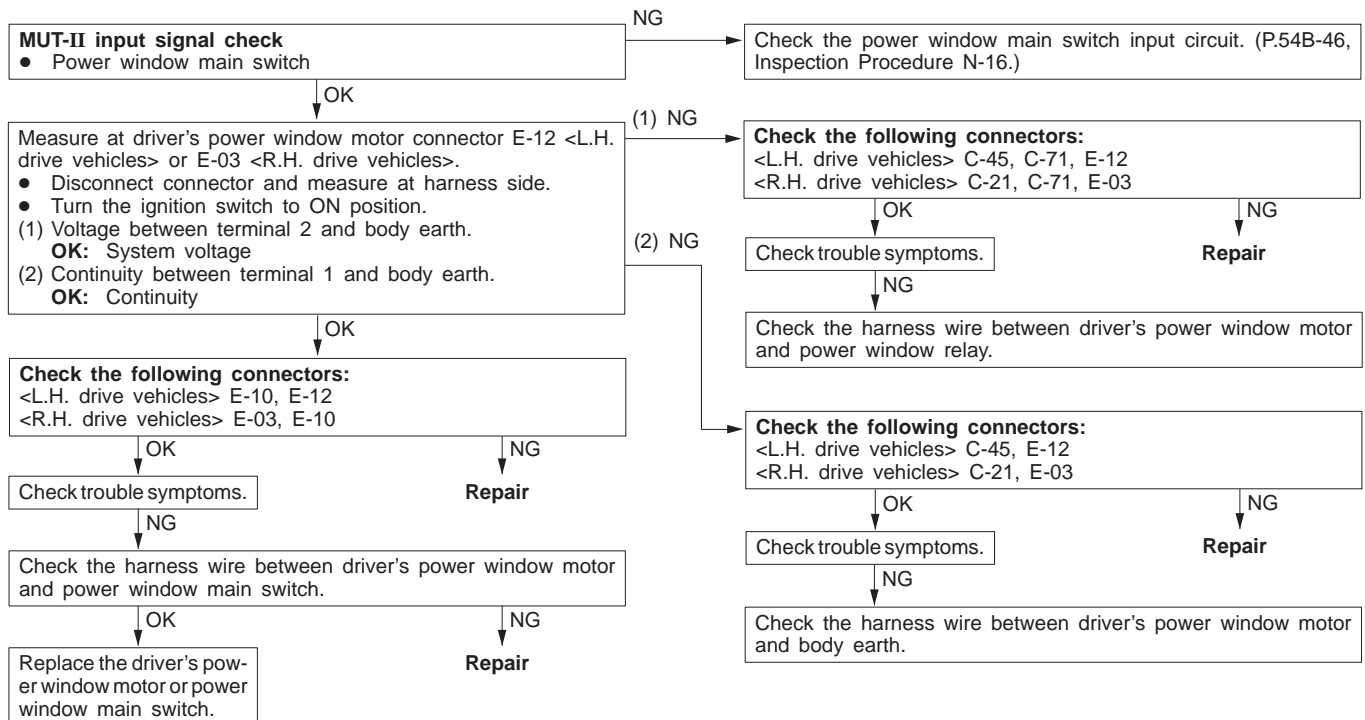

Inspection Procedure D-3

Power window: Power window sub switch can not operate passenger's window.	Probable cause
The cause is probably a malfunction of the power window main switch or driver's side power window motor, or an abnormality in the power supply circuit.	<ul style="list-style-type: none"> ● Malfunction of power window sub switch ● Malfunction of passenger's power window motor ● Malfunction of harness wire or connector

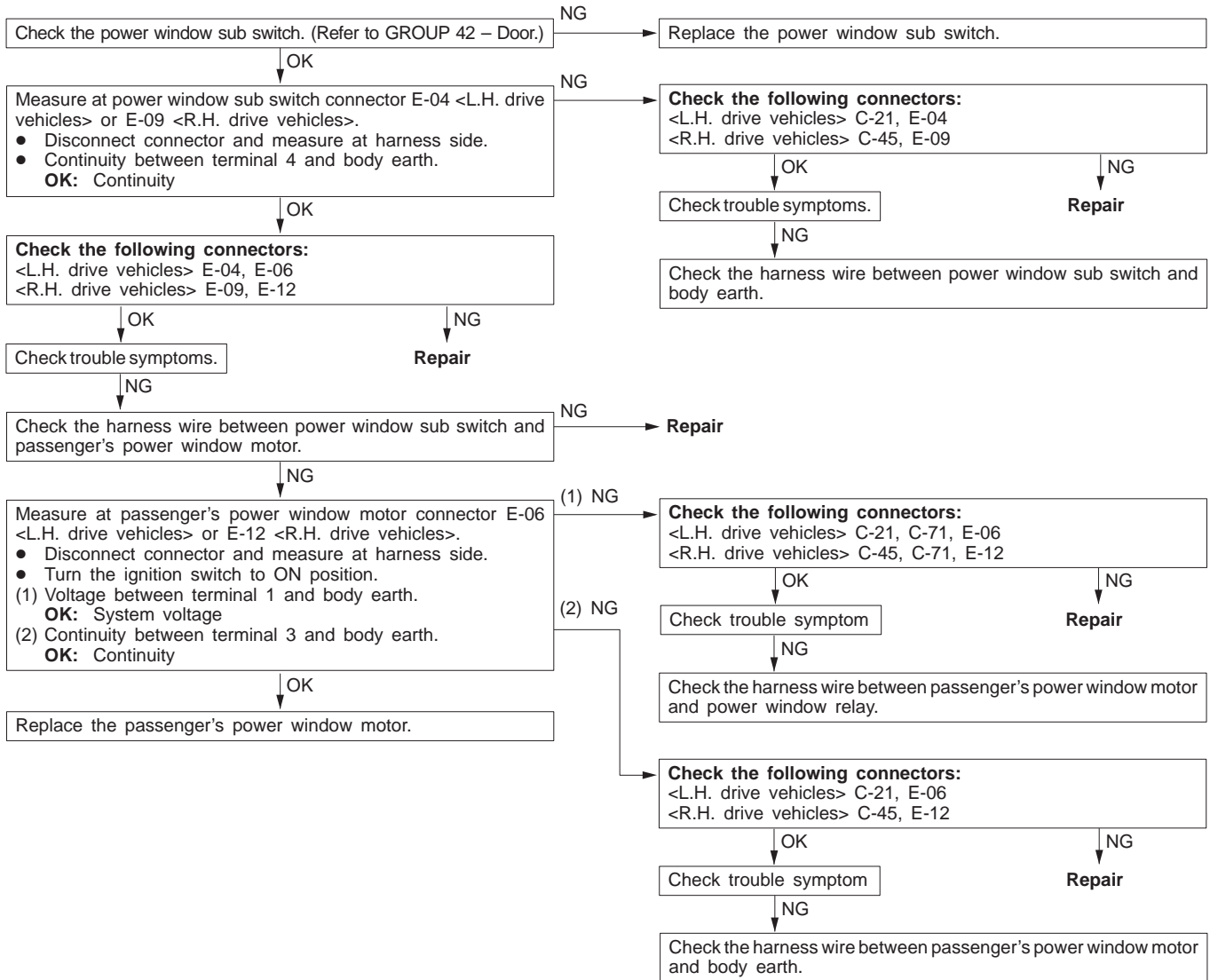

Inspection Procedure D-4

Power window: Power window main switch can not operate passenger's window.	Probable cause
The cause is probably a malfunction of the power window main switch or driver's side power window motor, or an abnormality in the power supply circuit.	<ul style="list-style-type: none"> ● Malfunction of power window main switch ● Malfunction of passenger's power window motor ● Malfunction of harness wire or connector

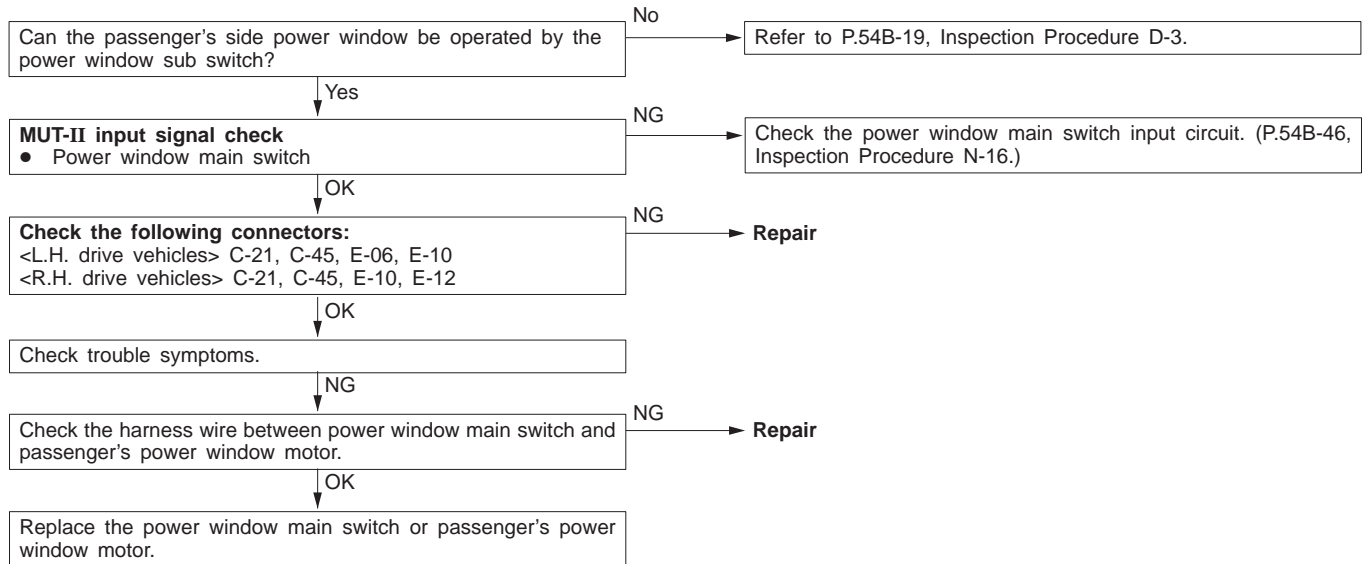

Inspection Procedure D-5

Power window: Power window timer function does not work normally.	Probable cause
The ETACS-ECU operates the power window timer function, based on the input signals from the following switches: <ul style="list-style-type: none"> ● Ignition switch (IG1) ● Driver's door switch If the function does not work normally, a defect on the relevant circuit or the ETACS-ECU may be suspected.	<ul style="list-style-type: none"> ● Malfunction of driver's door switch ● Malfunction of ETACS-ECU ● Malfunction of harness wire or connector

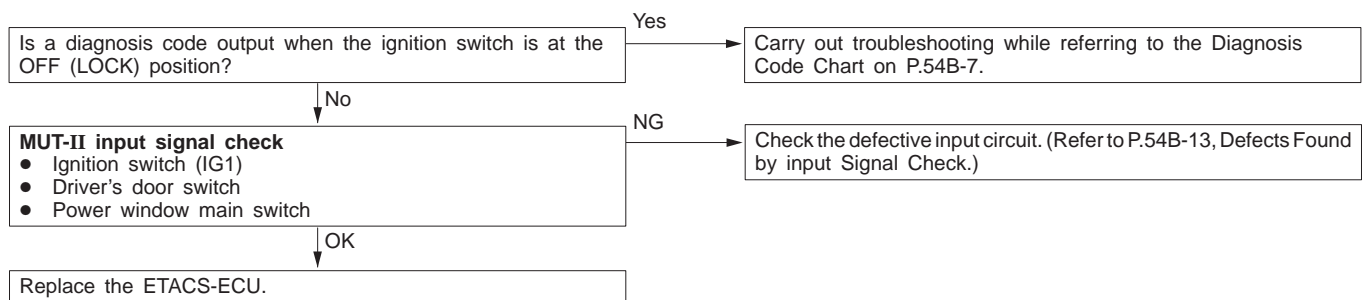

Inspection Procedure D-6

Power window: When the glass is raised, it then lowers automatically.	Probable cause
If the sliding resistance is too large when the glass is being raised, it is judged that something is jammed in the window, and the window is lowered by approximately 150 mm.	<ul style="list-style-type: none"> ● Incorrect window glass adjustment ● Glass slider is incorrectly installed or warped ● Malfunction of power window motor

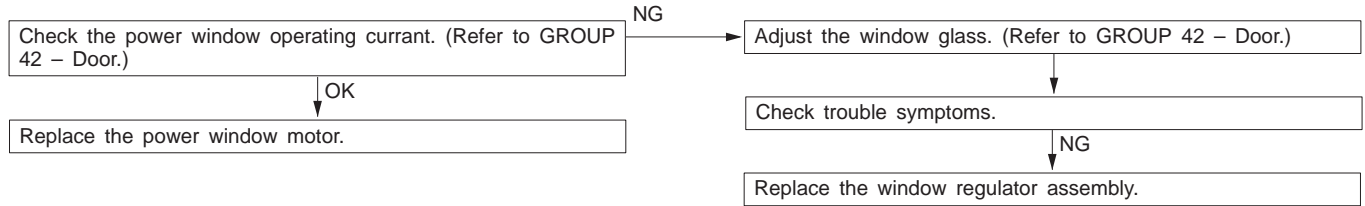

Inspection Procedure D-7

Power window: The glass is jammed in the window.	Probable cause
The cause may be a malfunction of the revolution detection sensor in the power window motor.	<ul style="list-style-type: none"> ● Malfunction of power window motor

Replace the power window motor.

Inspection Procedure D-8

Power window: When the glass is fully raised, it then lowers automatically.	Probable cause
The cause may be a malfunction of the revolution detection sensor in the power window motor.	<ul style="list-style-type: none"> ● Malfunction of power window motor

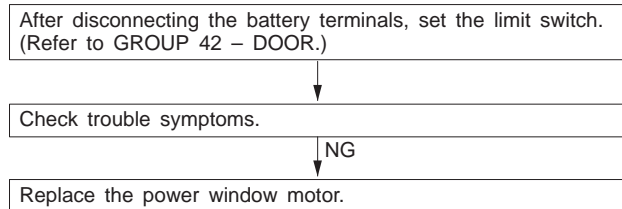

Inspection Procedure E-1

Keyless entry system: Keyless entry system does not operate.	Probable cause
The cause may be a malfunction of the receiver and transmitter communication system	<ul style="list-style-type: none"> ● Malfunction of transmitter ● Malfunction of ETACS-ECU

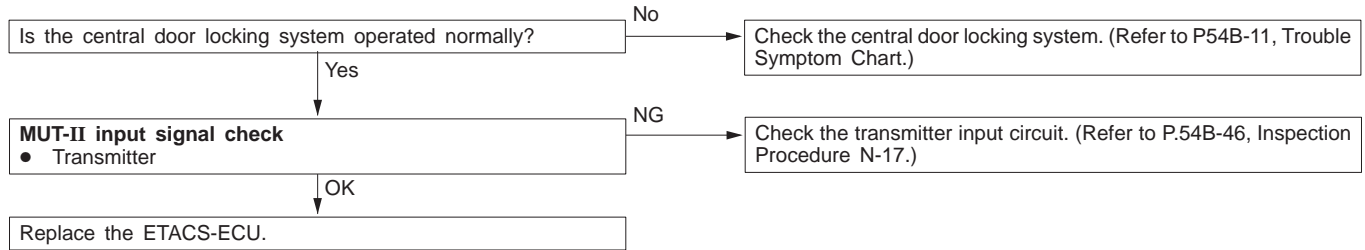

Inspection Procedure E-2

Keyless entry system: The room lamp and hazard warning lamps do not operate through the answerback function.	Probable cause
The hazard warning lamp answerback function can be selected by the driver's desire (can be deactivated). However, the room lamp answerback function can not be deactivated. If all of these device do not operate through the answerback function, the ETACS-ECU may be defective.	<ul style="list-style-type: none"> ● Malfunction of turn-signal lamp ● Malfunction of room lamp ● Malfunction of ETACS-ECU ● Malfunction of harness wire or connector

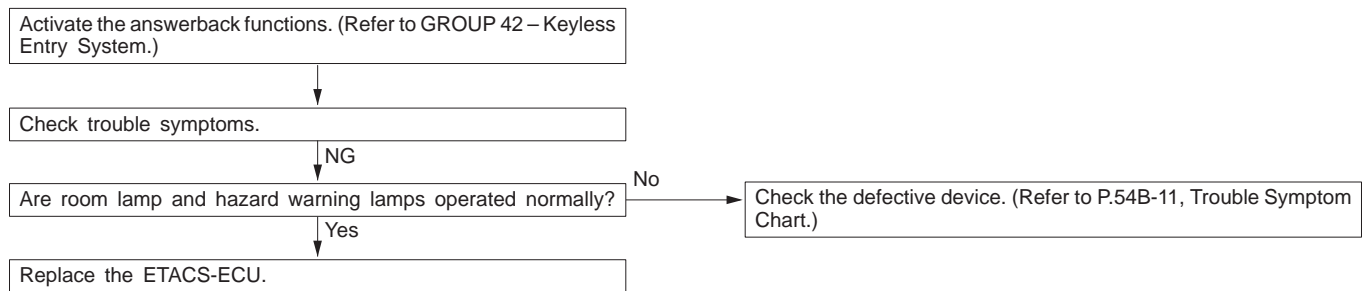

Inspection Procedure E-3

Keyless entry system: The encrypted code cannot be registered.	Probable cause
<p>The ETACS-ECU activates the encrypted code register mode according to the following switch signals.</p> <ul style="list-style-type: none"> ● Key reminder switch ● Hazard warning lamp switch <p>If the encrypted code register mode is not set, the relevant input signal circuit or the ETACS-ECU may be defective.</p> <p>If a transmitter can not be registered although the encrypted code register mode is set, the transmitter or the ETACS-ECU may be defective.</p>	<ul style="list-style-type: none"> ● Malfunction of key reminder switch ● Malfunction of hazard warning lamp switch ● Malfunction of transmitter ● Malfunction of ETACS-ECU ● Malfunction of harness wire or connector

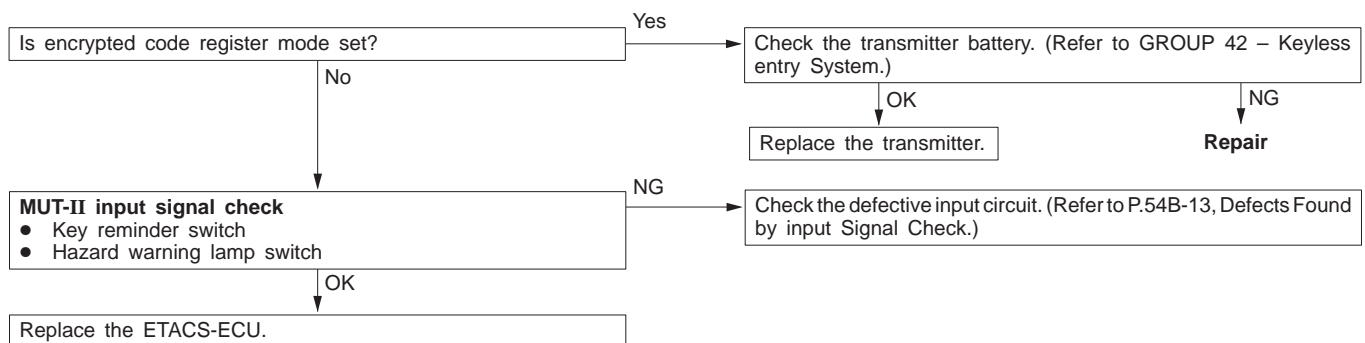

Inspection Procedure F-1

Windshield wiper and washer: Windshield wiper does not operate.	Probable cause
If the windshield wiper does not work at all, the windshield wiper motor, column switch or the front-ECU may be defective.	<ul style="list-style-type: none"> ● Malfunction of windshield wiper motor ● Malfunction of column switch ● Malfunction of front-ECU ● Malfunction of harness wire or connector

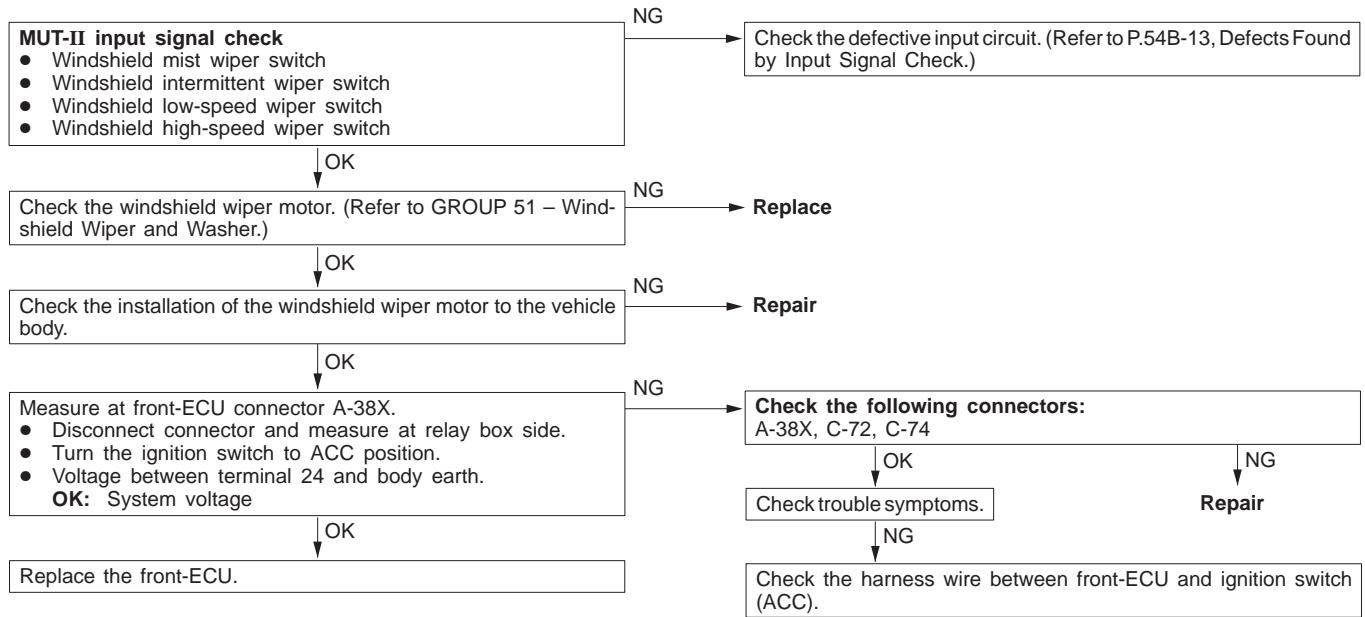

Inspection Procedure F-2

Windshield wiper and washer: Any of the windshield wiper switch positions is defective.	Probable cause
The windshield wiper motor, column switch or the front-ECU may be defective.	<ul style="list-style-type: none"> ● Malfunction of windshield wiper motor ● Malfunction of column switch ● Malfunction of front-ECU ● Malfunction of harness wire or connector

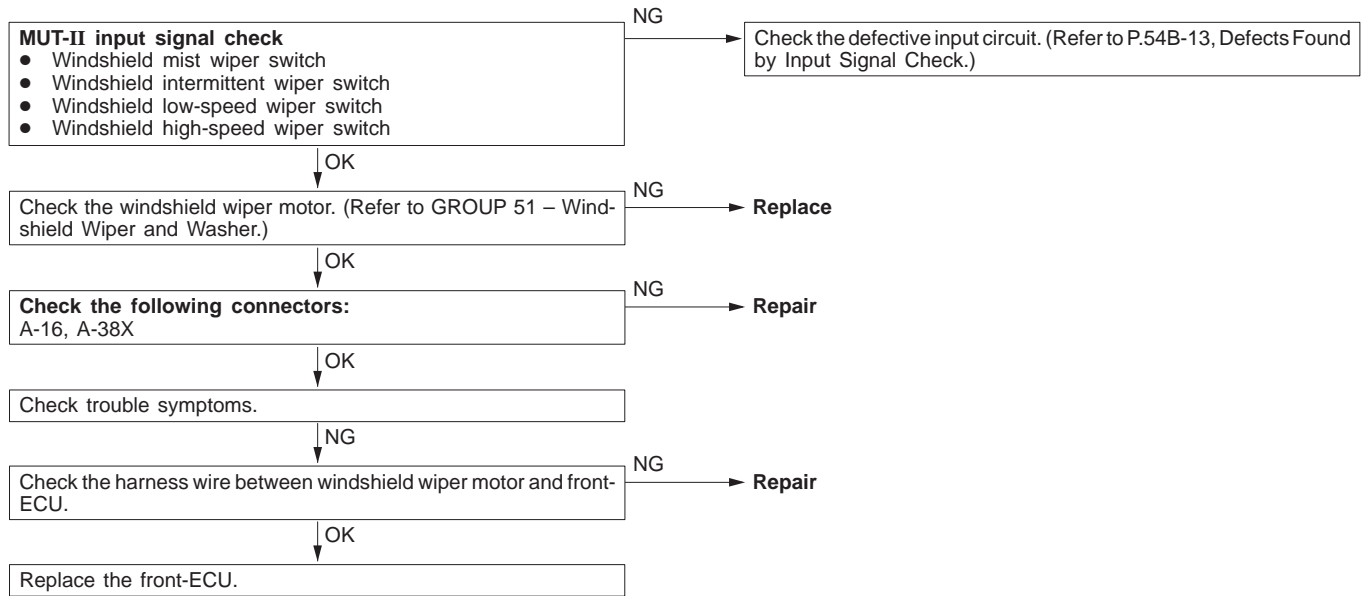

Inspection Procedure F-3

Windshield wiper and washer: Windshield wiper does not stop at the predetermined park position.	Probable cause
The windshield wiper motor or the front-ECU may be defective.	<ul style="list-style-type: none"> ● Malfunction of windshield wiper motor ● Malfunction of front-ECU ● Malfunction of harness wire or connector

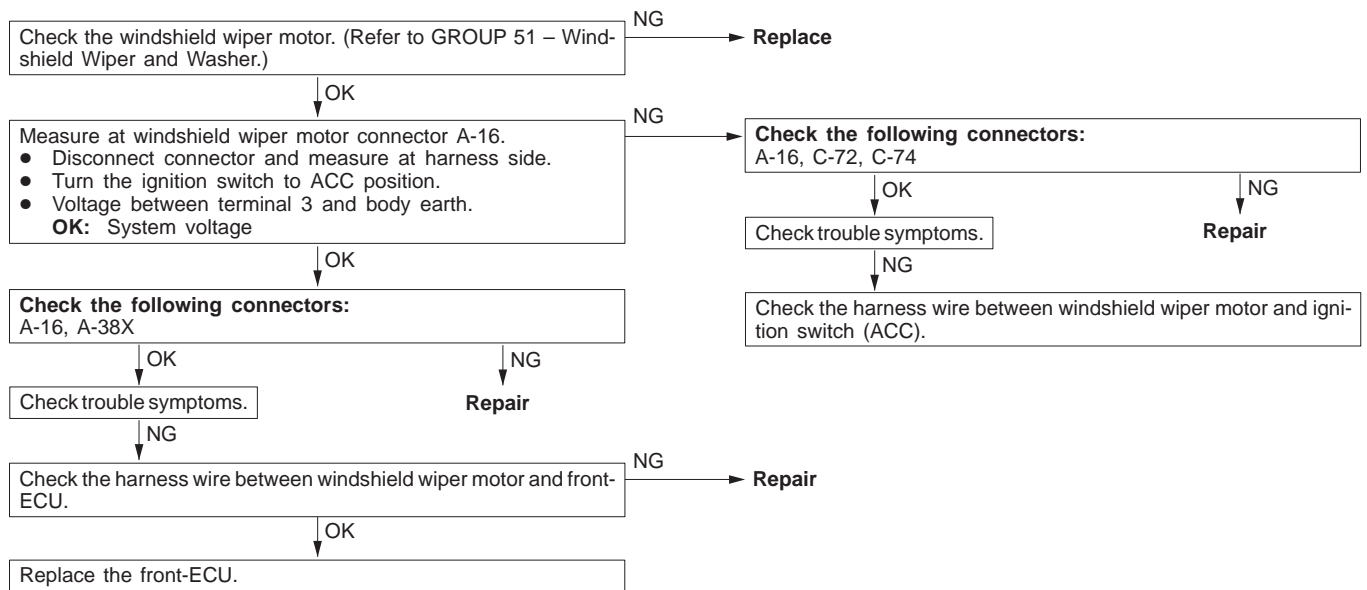

Inspection Procedure F-4

Windshield wiper and washer: Windshield intermittent wiper interval cannot be adjusted.	Probable cause
The ETACS-ECU calculates the intermittent wiper interval, and sends a signal to the front-ECU through the SWS communication line. If the signal is defective, the front-ECU will ignore the signal and set the intermittent wiper interval to 4 seconds.	<ul style="list-style-type: none"> ● Malfunction of column switch ● Malfunction of front-ECU ● Malfunction of ETACS-ECU ● Malfunction of harness wire or connector

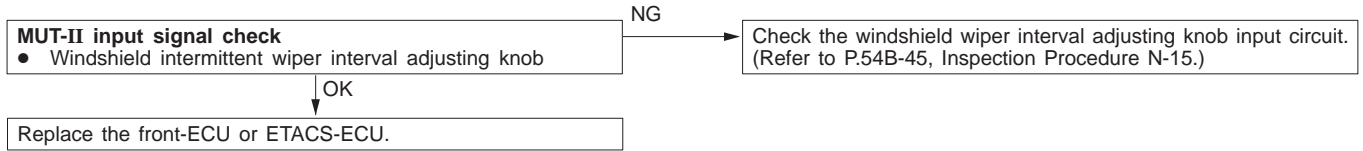

Inspection Procedure F-5

Windshield wiper and washer: Windshield washer does not work.	Probable cause
The windshield washer motor, the column switch or the front-ECU may be defective.	<ul style="list-style-type: none"> ● Malfunction of windshield washer motor ● Malfunction of column switch ● Malfunction of front-ECU ● Malfunction of harness wire or connector

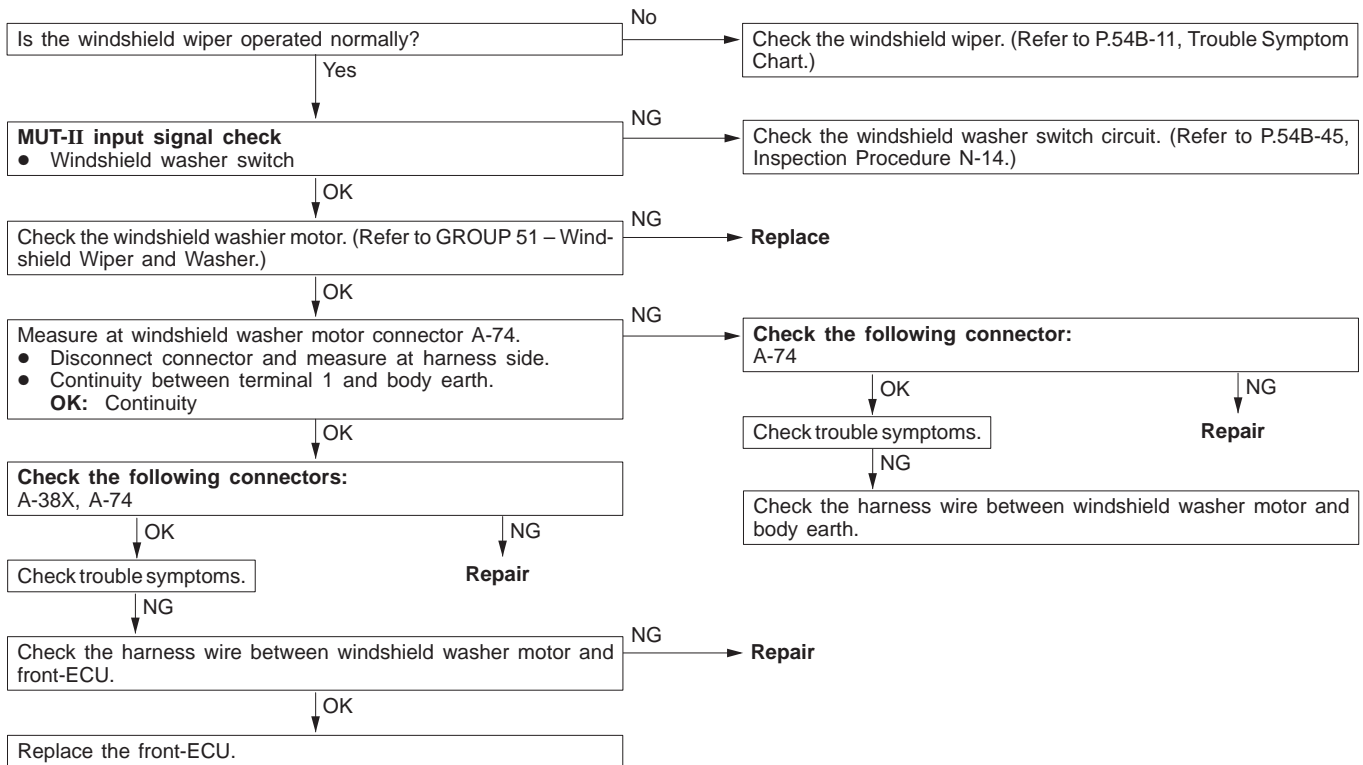

Inspection Procedure G-1

Rear wiper and washer: Rear wiper does not work normally.	Probable cause
The ETACS-ECU operates the rear wiper according to the input signals from the following switches: <ul style="list-style-type: none"> ● Ignition switch (ACC) ● Rear wiper switch If the rear wiper does not work normally, the relevant input signal circuit, the rear wiper motor, the column switch or the ETACS-ECU may be defective.	<ul style="list-style-type: none"> ● Malfunction of rear wiper motor ● Malfunction of column switch ● Malfunction of front-ECU ● Malfunction of harness wire or connector

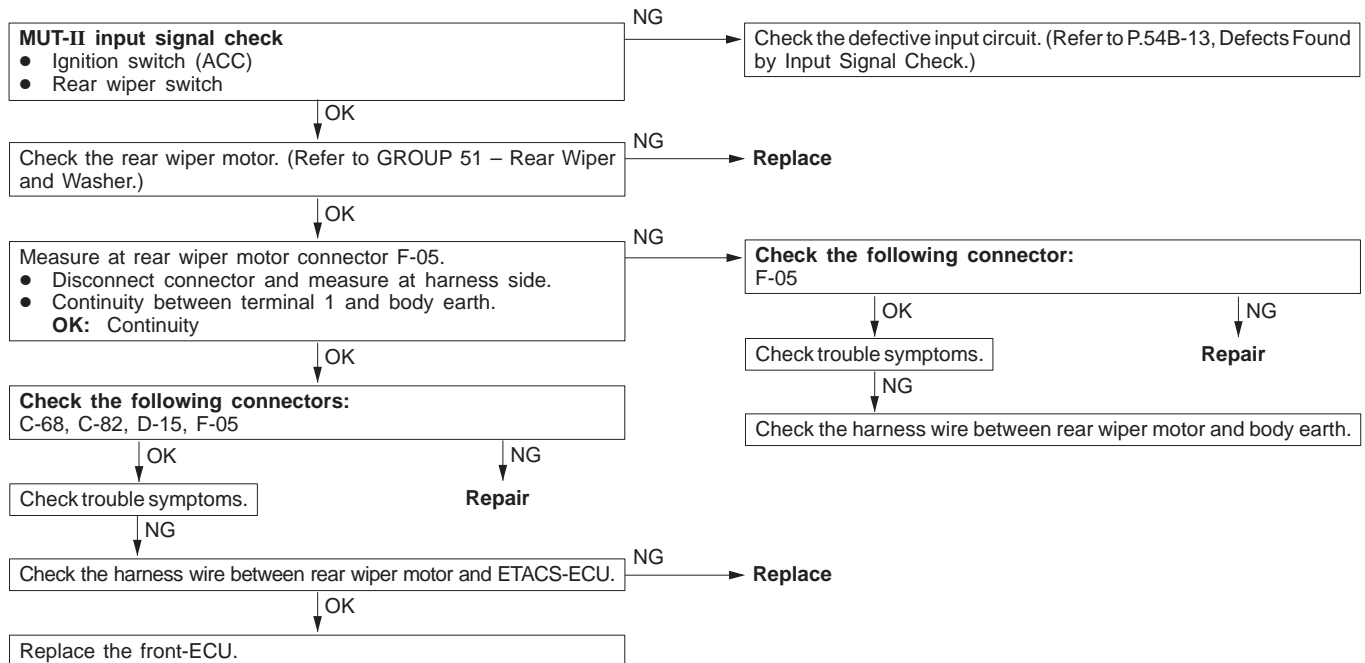

Inspection Procedure G-2

Rear wiper and washer: Rear wiper does not stop at the predetermined park position.	Probable cause
The rear wiper motor or the ETACS-ECU may be defective.	<ul style="list-style-type: none"> ● Malfunction of rear wiper motor ● Malfunction of front-ECU ● Malfunction of harness wire or connector

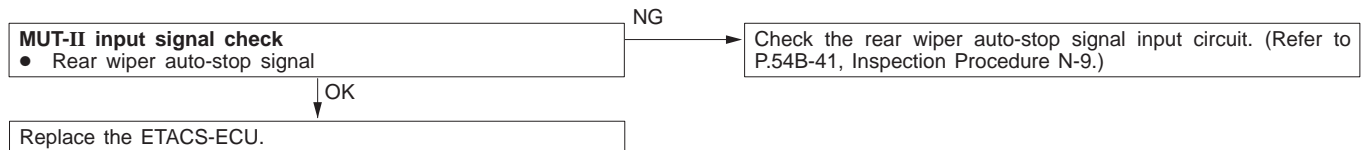

Inspection Procedure G-3

<p>Rear wiper and washer: When the shift lever <M/T> or selector lever <A/T> is moved to R position during the rear wiper operation, the rear wiper does not operate at the continuous mode.</p>	<p>Probable cause</p>
<p>The ETACS-ECU operates the rear wiper consecutively twice when the shift lever <M/T> or selector lever <A/T> is moved to R position while the rear wiper is turned on. If the rear wiper does not work consecutively twice, the back-up lamp switch <M/T> or the inhibitor switch (reverse) <A/T> may be defective.</p>	<ul style="list-style-type: none"> ● Malfunction of back-up lamp switch ● Malfunction of inhibitor switch ● Malfunction of ETACS-ECU ● Malfunction of harness wire or connector

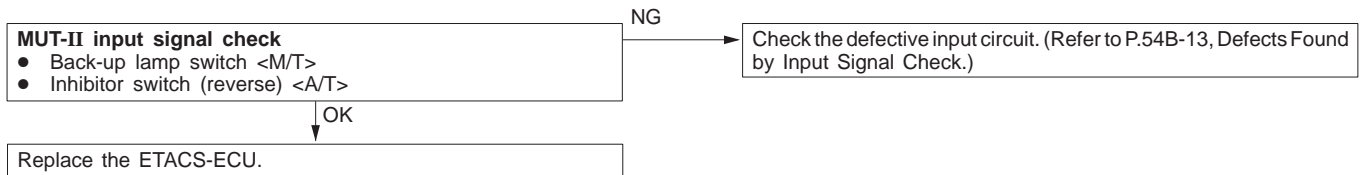

Inspection Procedure G-4

<p>Rear wiper and washer: Rear washer does not work.</p>	<p>Probable cause</p>
<p>The rear washer motor, the column switch or the ETACS-ECU may be defective.</p>	<ul style="list-style-type: none"> ● Malfunction of rear washer motor ● Malfunction of column switch ● Malfunction of ETACS-ECU ● Malfunction of harness wire or connector

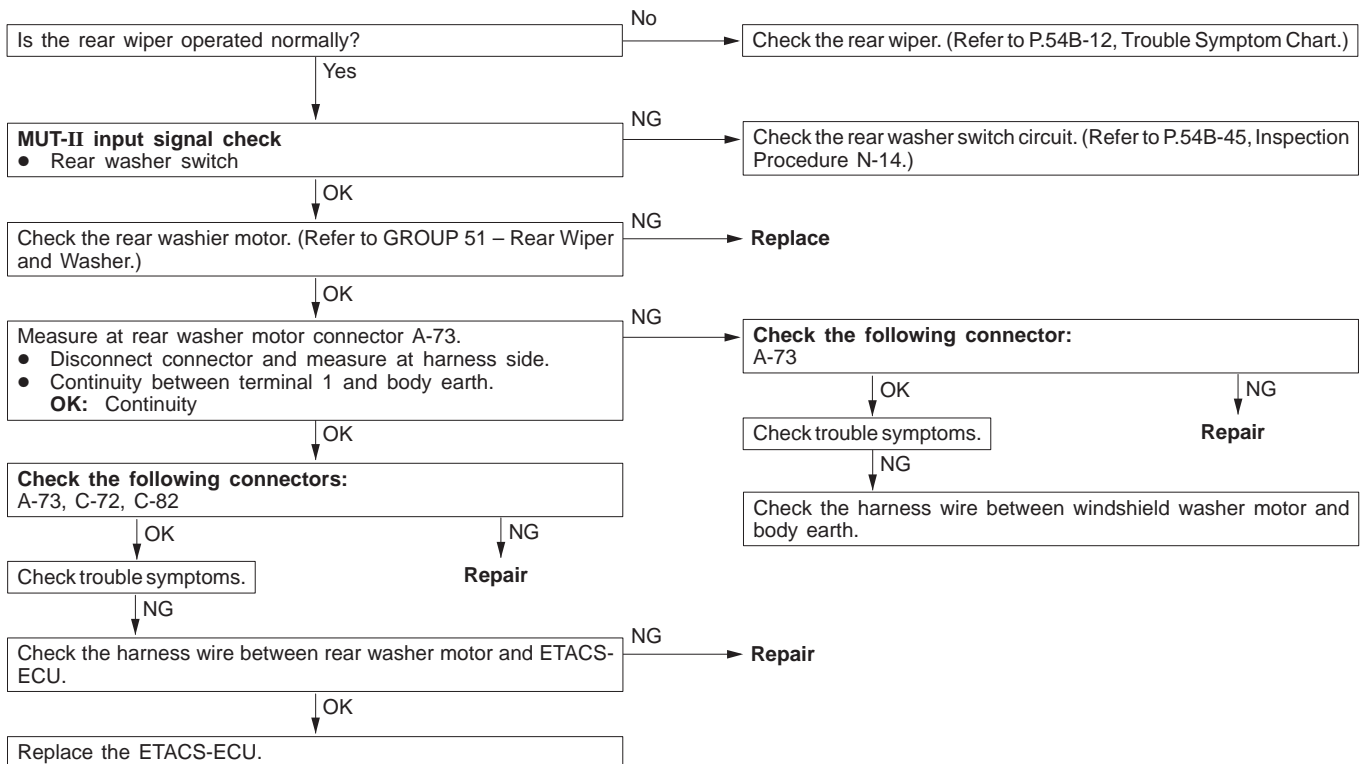

Inspection Procedure H-1

Headlamp washer: Headlamp washer does not work.	Probable cause
The front-ECU operates the headlamp washers if the headlamp washer switch is turned to ON while the headlamp relays (low and high) are ON and the ignition switch is at the ACC or ON position. If the headlamp washer does not work normally, the headlamp washer motor, the column switch or the front-ECU may be defective.	<ul style="list-style-type: none"> ● Malfunction of headlamp washer motor ● Malfunction of column switch ● Malfunction of front-ECU ● Malfunction of harness wire or connector

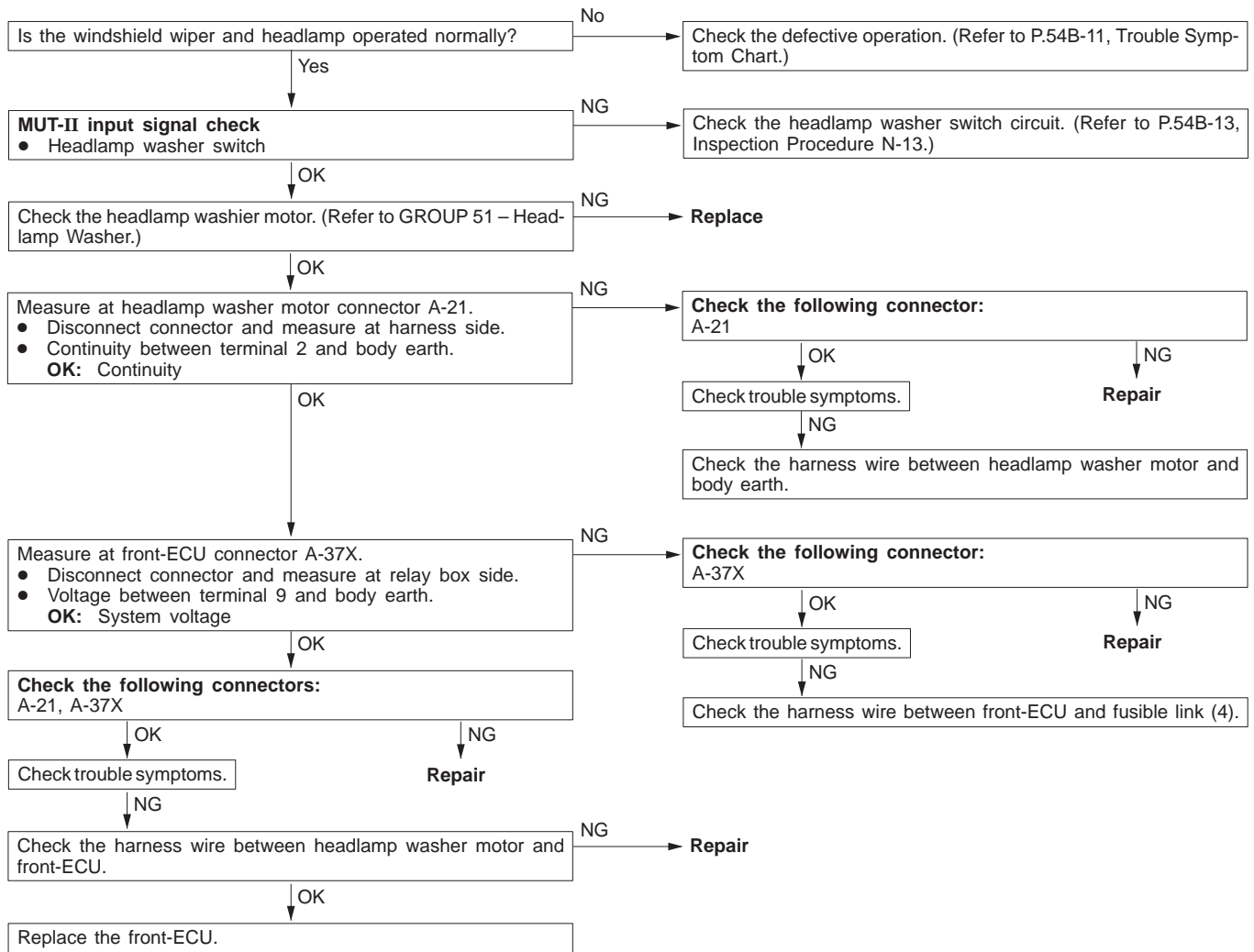

Inspection Procedure I-1

Headlamp, tail lamp: Tail lamp do not illuminate.	Probable cause
The column switch or the front-ECU may be defective.	<ul style="list-style-type: none"> • Malfunction of column switch • Malfunction of front-ECU • Malfunction of harness wire or connector

NOTE

If only one lamp does not illuminate, the harness wire between the lamp and front-ECU may be defective or the light bulb may be burned out. In this case, check the tail lamp circuit.

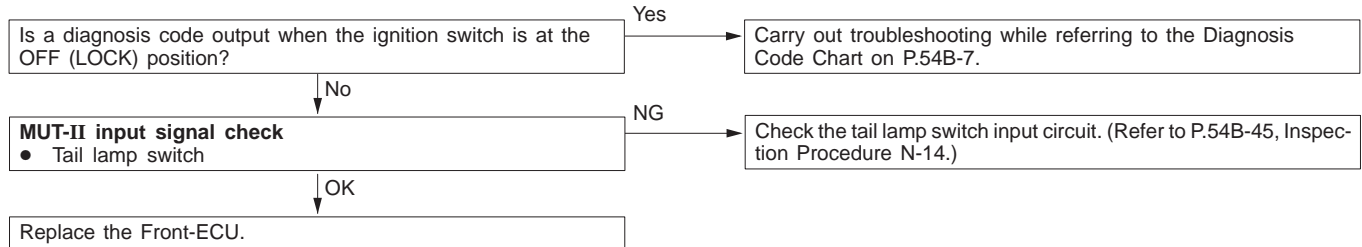

Inspection Procedure I-2

Headlamp, tail lamp: Headlamps (low-beam) do not illuminate.	Probable cause
The column switch or the front-ECU may be defective.	<ul style="list-style-type: none"> • Malfunction of column switch • Malfunction of front-ECU • Malfunction of harness wire or connector

NOTE

If only one of the headlamps (low-beam) does not illuminate, the harness wire between the headlamp and front-ECU may be defective or the headlamp bulb may be burned out. In this case, check the headlamp circuit.

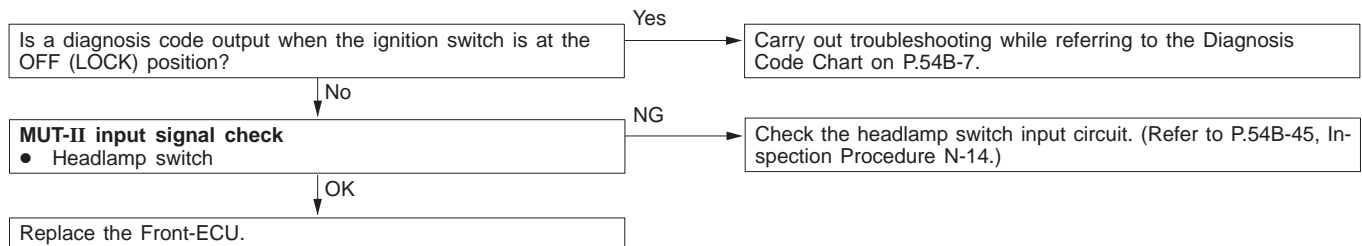

Inspection Procedure I-3

Headlamp, tail lamp: Headlamps (high-beam) do not illuminate.	Probable cause
The column switch or the front-ECU is suspected to be defective.	<ul style="list-style-type: none"> ● Malfunction of column switch ● Malfunction of front-ECU ● Malfunction of harness wire or connector

NOTE

If only one of the headlamps (high-beam) does not illuminate, the harness wire between the headlamp and front-ECU may be defective or the headlamp bulb may be burned out. In this case, check the headlamp circuit.

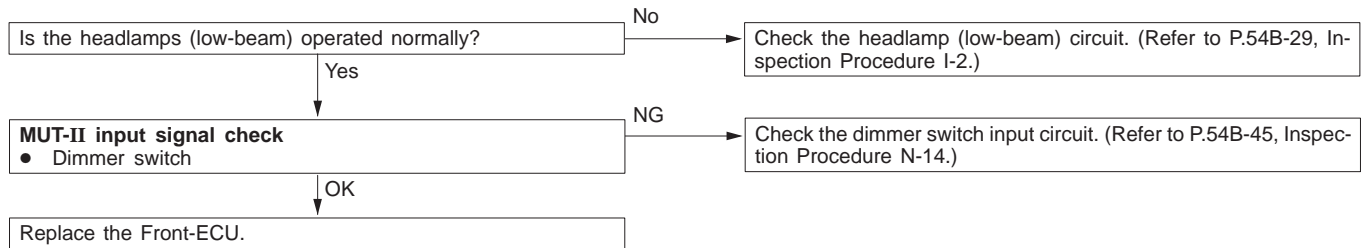

Inspection Procedure I-4

Headlamp, tail lamp: Headlamps do not illuminate when the passing switch is operated.	Probable cause
If the headlamps (low-beam and high-beam) are defective, the column switch or the front-ECU is suspected to be defective.	<ul style="list-style-type: none"> ● Malfunction of column switch ● Malfunction of front-ECU ● Malfunction of harness wire or connector

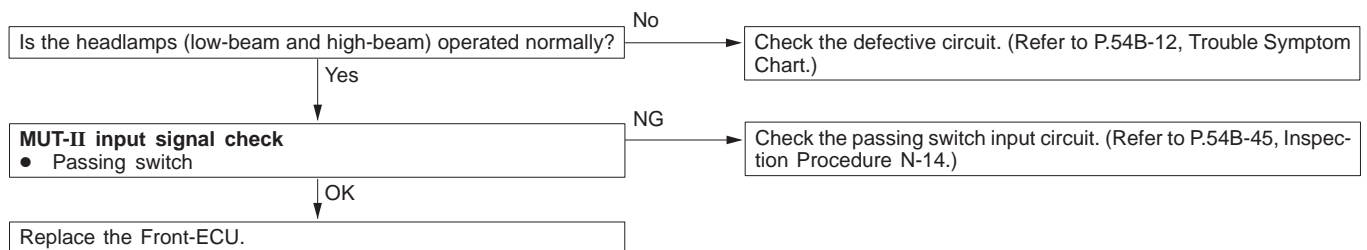

Inspection Procedure I-5

Headlamp, tail lamp: The headlamp auto-cut function does not work normally.	Probable cause
<p>The ETACS-ECU operates the headlamp auto-cut function, based on the signals from the following switch:</p> <ul style="list-style-type: none"> ● Ignition switch (IG1) ● Driver's door switch ● Tail lamp switch ● Headlamp switch <p>If the function does work normally, a defect on relevant input circuits, the ETACS-ECU or the front-ECU is suspected.</p>	<ul style="list-style-type: none"> ● Malfunction of driver's door switch ● Malfunction of column switch. ● Malfunction of front-ECU ● Malfunction of harness wire or connector

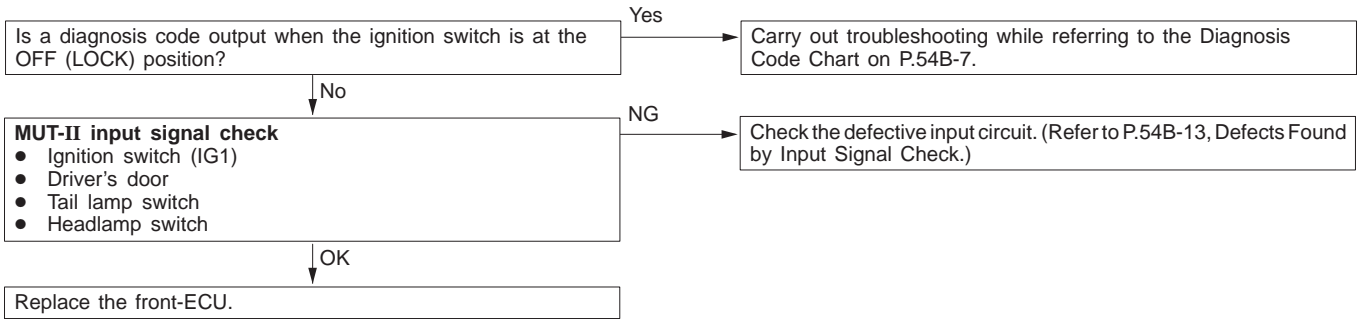

Inspection Procedure I-6

Headlamp, tail lamp: Headlamps dimmer switch auto-reset function does not work normally.	Probable cause
<p>The headlamp dimmer switch auto-reset function is controlled by the front-ECU. If a defect appears, the front-ECU may be defective.</p>	<ul style="list-style-type: none"> ● Malfunction of front-ECU

Replace the front-ECU.

Inspection Procedure I-7

Headlamp, tail lamp: Daytime running lamp (DRL) function does not work.	Probable cause
<p>The headlamp dimmer switch auto-reset function is controlled by the front-ECU. If a defect appears, the front-ECU may be defective.</p>	<ul style="list-style-type: none"> ● Malfunction of ETACS-ECU ● Malfunction of front-ECU ● Malfunction of harness wire or connector.

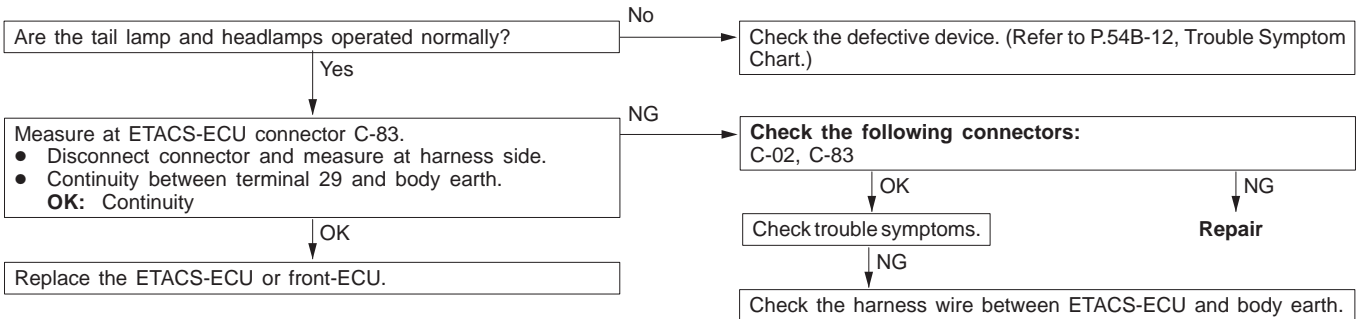

Inspection Procedure J-1

Flasher timer: Turn-signal lamp do not flash when the turn-signal lamp switch is turned on.	Probable cause
<p>The ETACS-ECU makes the turn-signal lamps flash, based on the input signals from the following switched:</p> <ul style="list-style-type: none"> ● Ignition switch (IG1) ● Turn-signal lamp switch <p>If the turn-signal lamps do not flash normally, a defect on the relevant circuits or the ETACS-ECU may be suspected.</p> <p>If the hazard warning lamps also do not flash, a defect in the ETACS-ECU power supply line specific to the turn-signal lamps is suspected.</p>	<ul style="list-style-type: none"> ● Malfunction of column switch ● Malfunction of ETACS-ECU ● Malfunction of harness wire or connector.

NOTE

If only one of the turn-signal lamp does not flash, the harness wire between the lamp and ETACS-ECU may be defective or the lamp bulb may be burned out. In this case, check the turn-signal lamp and hazard warning lamp circuit.

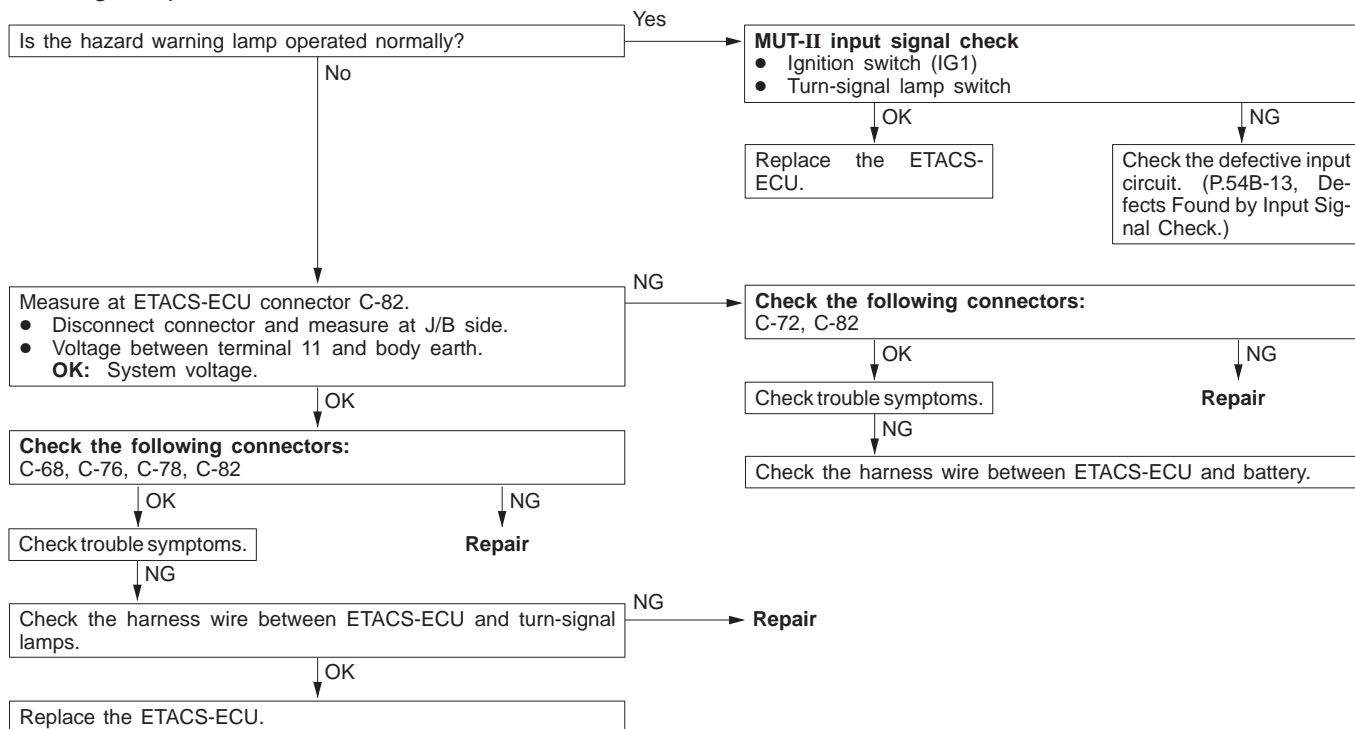

Inspection Procedure J-2

Flasher timer: Hazard warning lamp do not flash when the hazard warning lamp switch is turned on.	Probable cause
<p>The ETACS-ECU makes the turn-signal lamps flash, base on the input signals from the hazard warning lamp switch. If the turn-signal lamps do not flash normally, the hazard warning lamp switch input circuit or the ETACS-ECU may be defective.</p>	<ul style="list-style-type: none"> ● Malfunction of hazard warning lamp switch ● Malfunction of ETACS-ECU ● Malfunction of harness wire or connector.

NOTE

If only one of the turn-signal lamp does not flash, the harness wire between the lamp and ETACS-ECU may be defective or the lamp bulb may be burned out. In this case, check the turn-signal lamp and hazard warning lamp circuit.

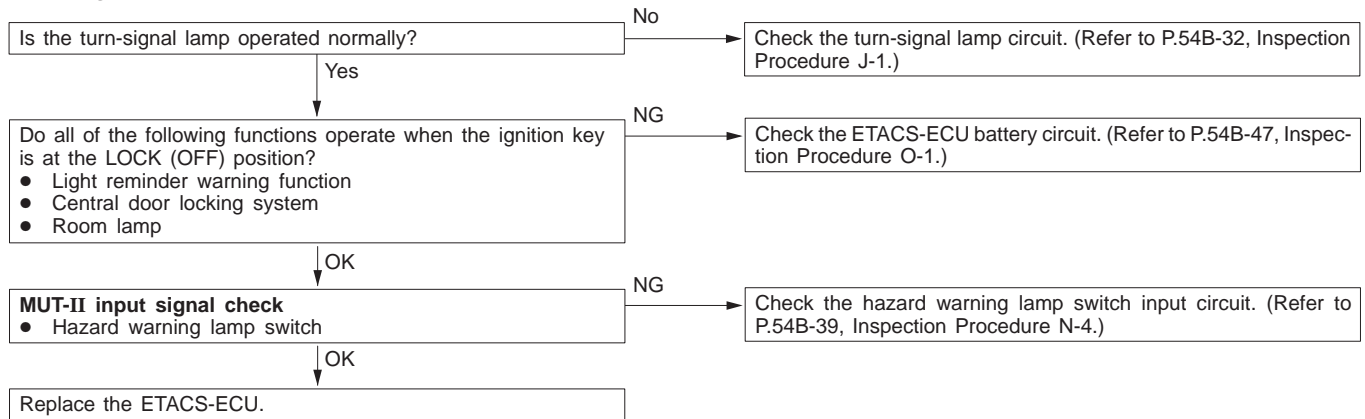

Inspection Procedure K-1

Front fog lamp: Front fog lamps do not illuminate when the front fog lamp switch is turned on.	Probable cause
If the tail lamps illuminate normally, the front fog lamp switch, the front fog lamp relay, the front-ECU or the ETACS-ECU may be defective.	<ul style="list-style-type: none"> ● Malfunction of front fog lamp switch ● Malfunction of front fog lamp relay ● Malfunction of front-ECU ● Malfunction of ETACS-ECU ● Malfunction of harness wire or connector.

NOTE

If only one of the front fog lamp or fog lamp indicator lamp does not illuminate, the harness wire between the lamp and front fog lamp relay may be defective or the lamp bulb may be burned out. In this case, check the front fog lamp circuit.

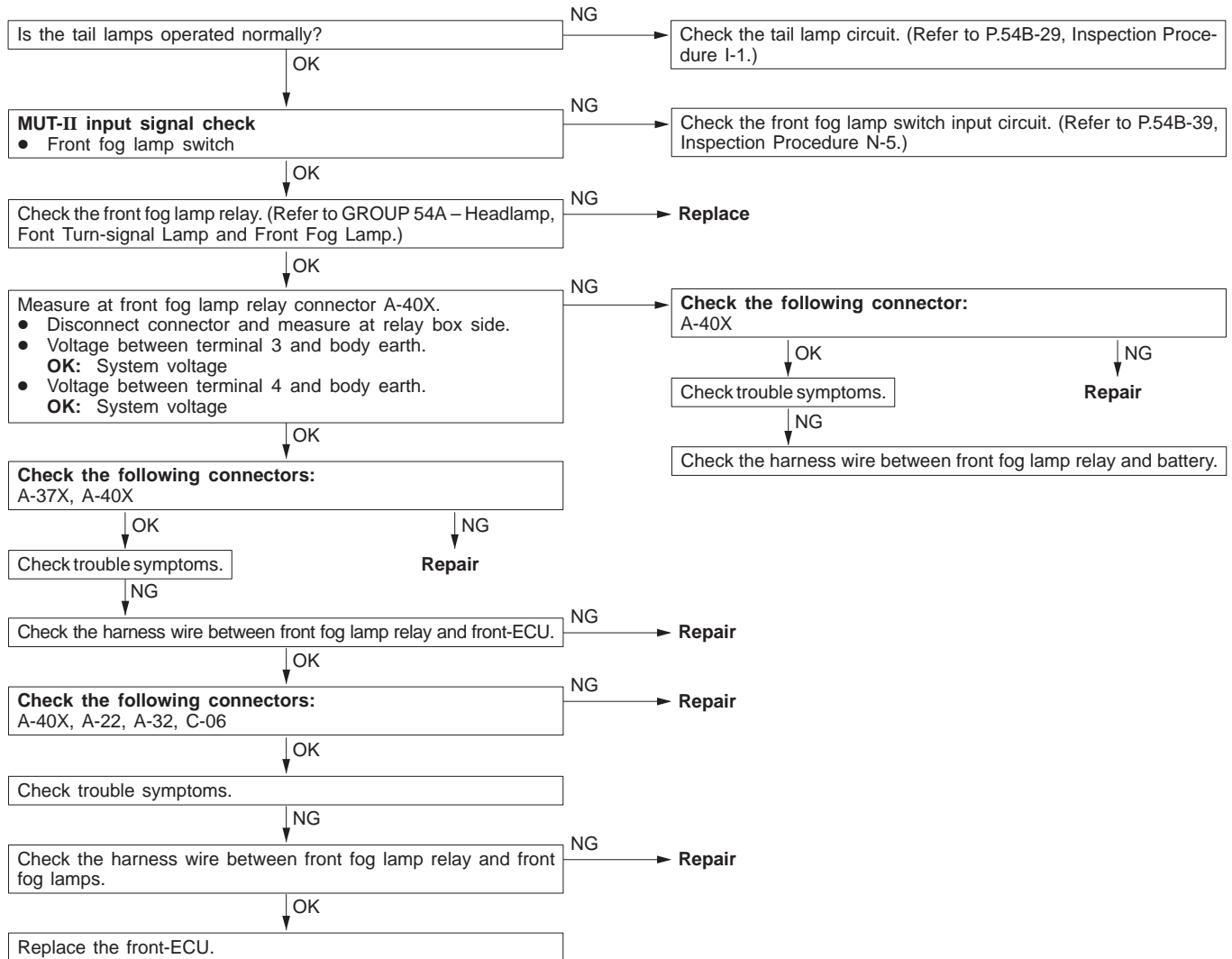

Inspection Procedure K-2

Front fog lamp: Front fog lamp do not go out when the tail lamps are turned off while the fog lamps are on.	Probable cause
If the malfunction above occurs, the ETACS-ECU may be defective.	<ul style="list-style-type: none"> ● Malfunction of ETACS-ECU

Replace the ETACS-ECU.

Inspection Procedure L-1

Rear fog lamp: Rear fog lamps do not illuminate when the rear fog lamp switch is turned on.	Probable cause
If the headlamps and front fog lamp <vehicles with front fog lamp> illuminate normally, the rear fog lamp switch, the rear fog lamp relay or the ETACS-ECU may be defective.	<ul style="list-style-type: none"> ● Malfunction of rear fog lamp switch ● Malfunction of rear fog lamp relay ● Malfunction of ETACS-ECU ● Malfunction of harness wire or connector.

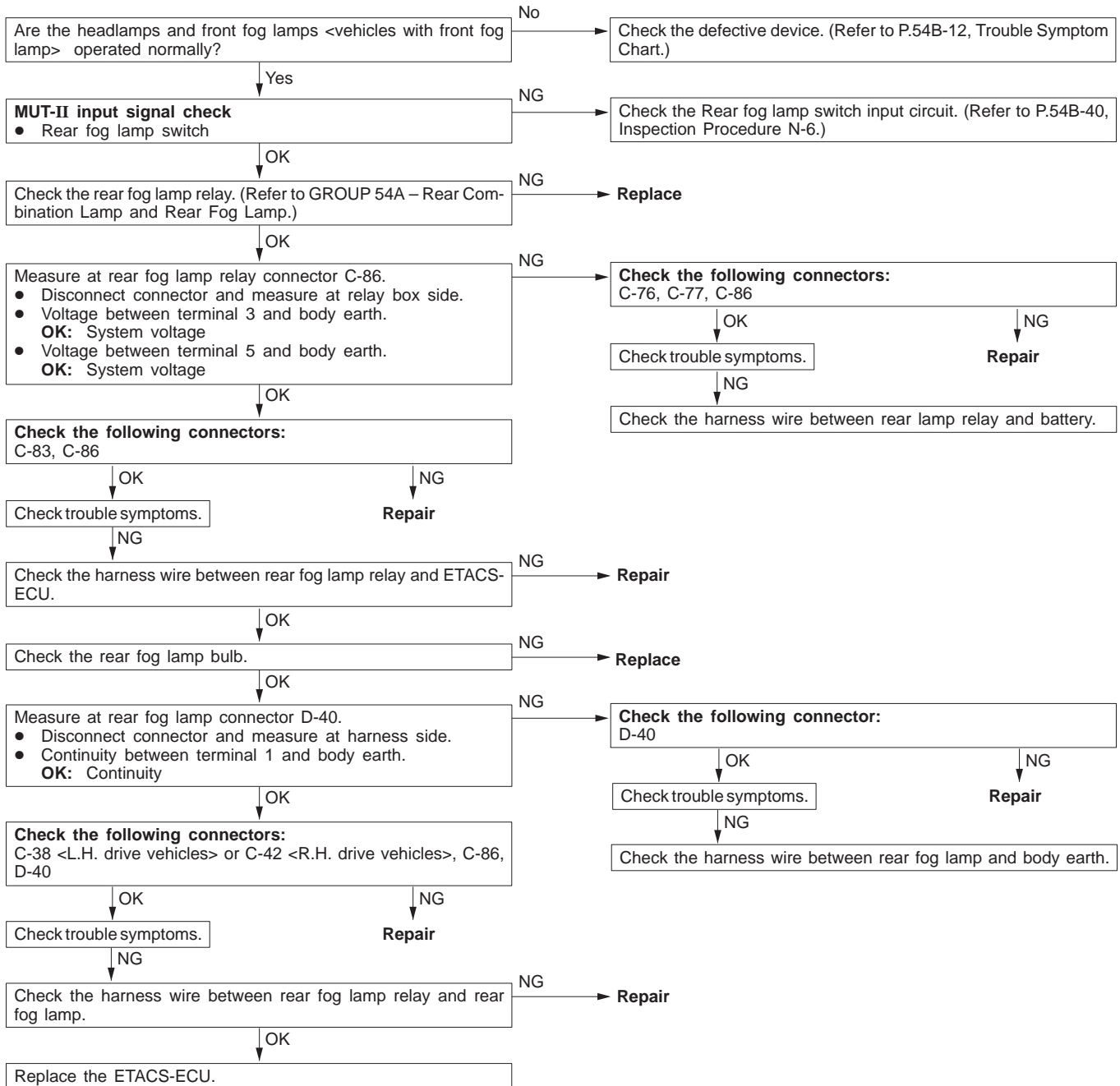

Inspection Procedure L-2

<p>Rear fog lamp: Rear fog lamp do not go out when the headlamps and front fog lamps <vehicles with front fog lamp> are turned off while the fog lamps are on.</p>	<p>Probable cause</p>
<p>If the malfunction above occurs, the ETACS-ECU may be defective.</p>	<ul style="list-style-type: none"> ● Malfunction of ETACS-ECU

Replace the ETACS-ECU.

Inspection Procedure M-1

<p>Room lamp: The room lamp does not illuminate.</p>	<p>Probable cause</p>
<p>If the room lamp does not illuminate at all, the room lamp bulb may be burned out, or the power supply circuit or the ETACS-ECU may be defective.</p>	<ul style="list-style-type: none"> ● Malfunction of room lamp ● Malfunction of ETACS-ECU ● Malfunction of harness wire or connector

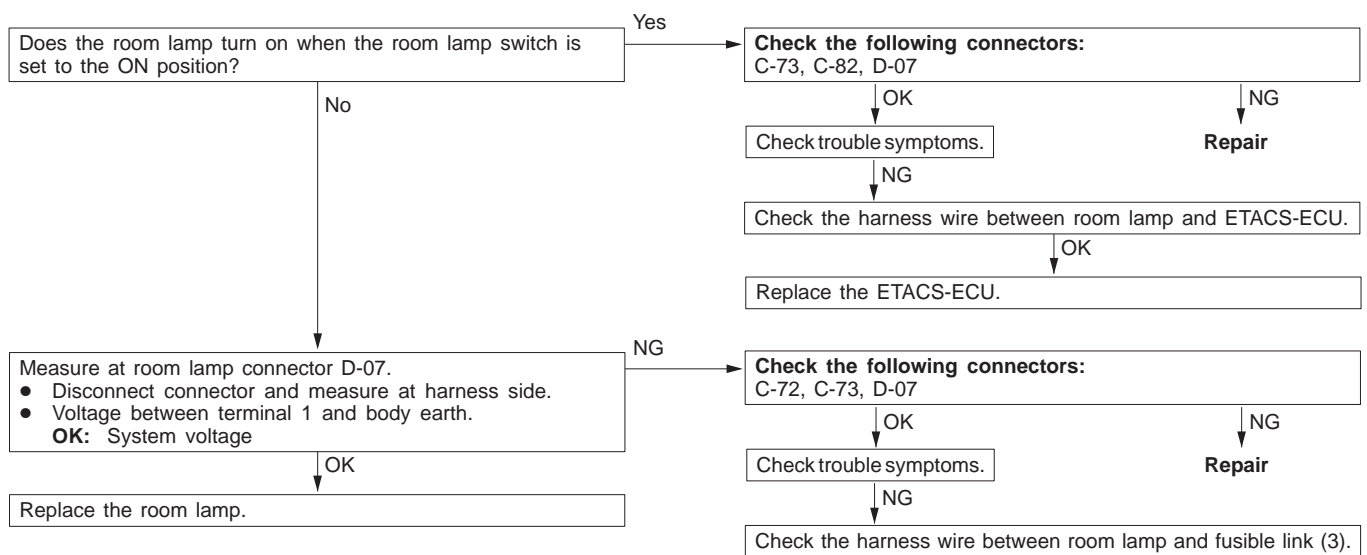

Inspection Procedure M-2

Room lamp: The room lamp dimming function does not work normally.	Probable cause
<p>The ETACS-ECU dims the room lamp according to the input signals from the following switches:</p> <ul style="list-style-type: none"> ● Ignition switch (IG1) ● Key reminder switch ● Driver's door switch ● Door switches ● Driver's door lock actuator switch <vehicles with keyless entry system> <p>If the Room lamp does not be dimmed normally, the relevant input signal circuit or the ETACS-ECU may be defective.</p>	<ul style="list-style-type: none"> ● Malfunction of key reminder switch ● Malfunction of driver's door switch ● Malfunction of door switches ● Malfunction of driver's door lock actuator switch ● Malfunction of ETACS-ECU ● Malfunction of harness wire or connector

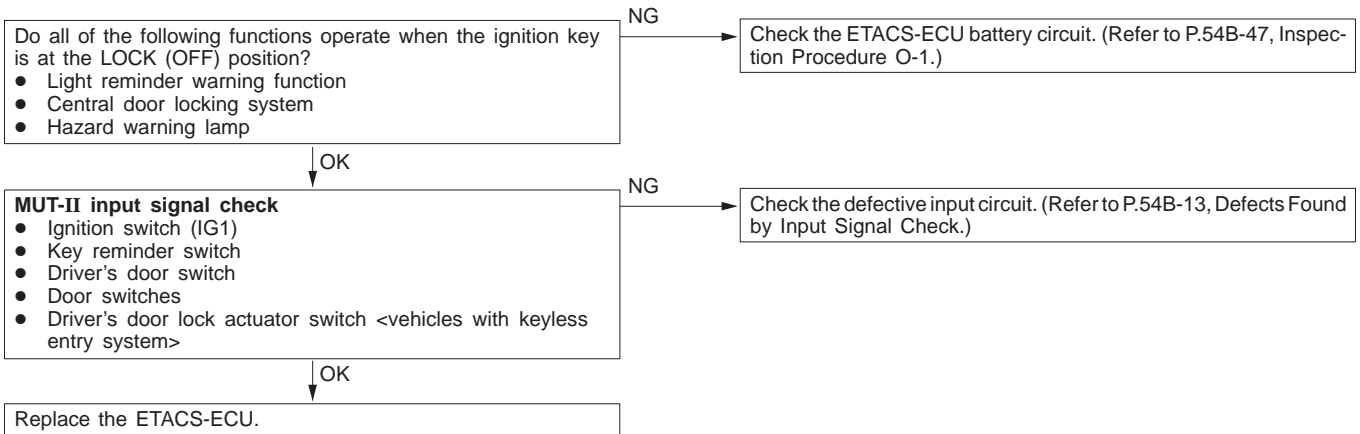

Inspection Procedure N-1

Ignition switch (ACC) signal is not sent to the ETACS-ECU.	Probable cause
<p>The ignition switch (ACC) input signal is used to operate the following devices. If the signal fails, these devices will not work normally.</p> <ul style="list-style-type: none"> ● Windshield wiper and washer ● Rear wiper and washer ● Headlamp washer <vehicles with headlamp washer> 	<ul style="list-style-type: none"> ● Malfunction of ETACS-ECU ● Malfunction of harness wire or connector

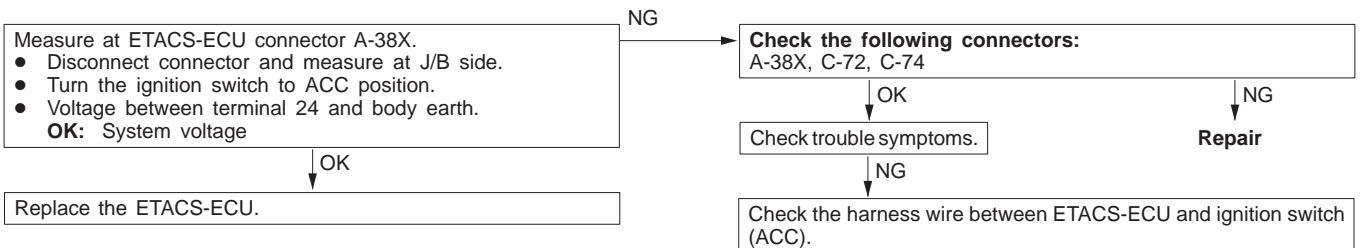

Inspection Procedure N-2

Ignition switch (IG1) signal is not sent to the ETACS-ECU.	Probable cause
<p>The ignition switch (IG1) input signal is used to operate the following devices. If the signal fails, these devices will not work normally.</p> <ul style="list-style-type: none"> • Light reminder alarm function • Power window timer function <vehicles with power window> • Headlamp auto-cut function • Turn-signal lamp • Room lamp dimming function 	<ul style="list-style-type: none"> • Malfunction of ETACS-ECU • Malfunction of harness wire or connector

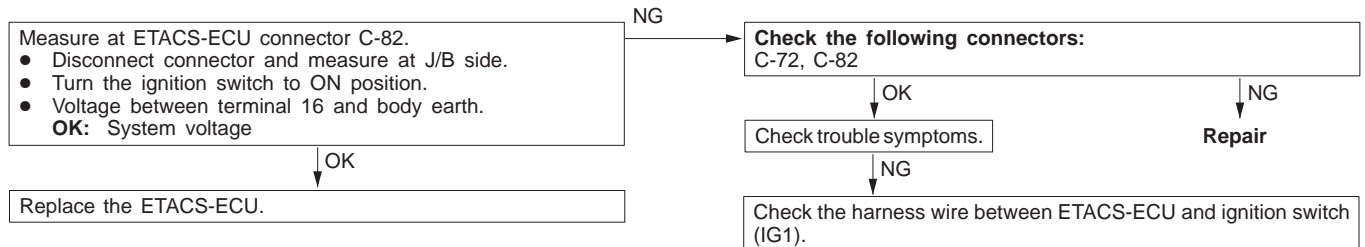

Inspection Procedure N-3

Key reminder switch signal is not sent to the ETACS-ECU.	Probable cause
<p>The key reminder switch input signal is used to operate the following devices. If the signal fails, these devices will not work normally.</p> <ul style="list-style-type: none"> • Forgotten key prevention function <Vehicles with keyless entry system> • Keyless entry system <Vehicles with keyless entry system> • Room lamp dimming function 	<ul style="list-style-type: none"> • Malfunction of key reminder switch • Malfunction of ETACS-ECU • Malfunction of harness wire or connector

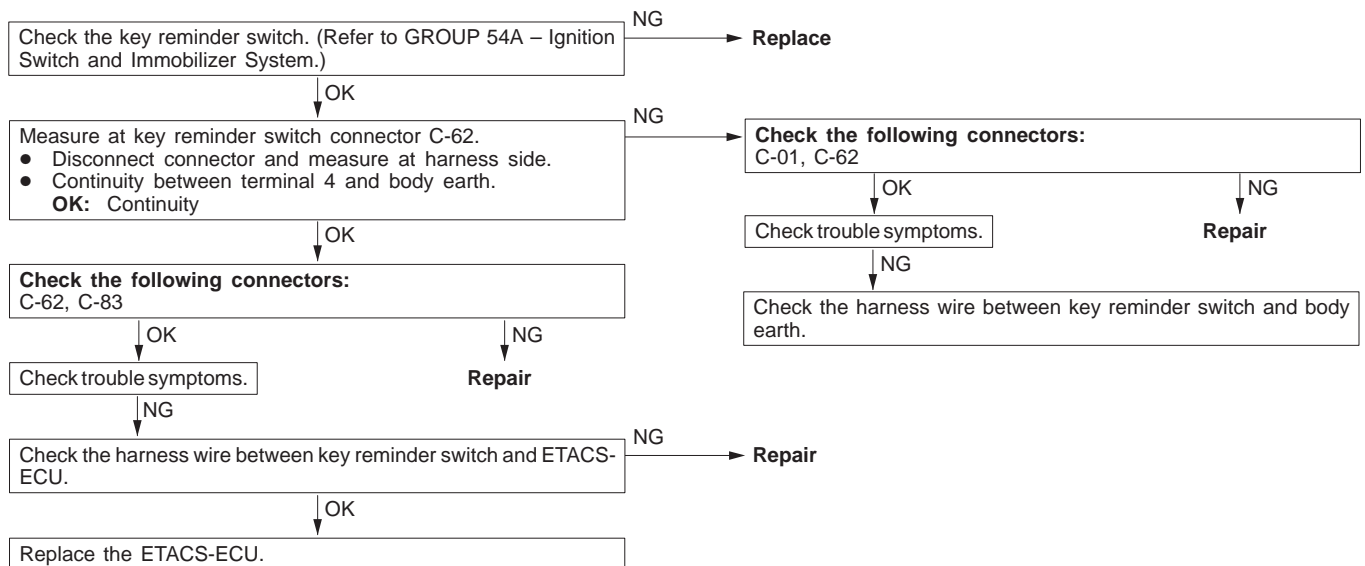

Inspection Procedure N-4

Hazard warning lamp switch signal is not sent to the ETACS-ECU.	Probable cause
The hazard warning lamp switch input signal is used to operate the following devices. If the signal fails, these devices will not work normally. <ul style="list-style-type: none"> • Hazard warning lamp • Keyless entry system (Registering the encrypted code) <vehicles with keyless entry system> 	<ul style="list-style-type: none"> • Malfunction of hazard warning lamp switch • Malfunction of ETACS-ECU • Malfunction of harness wire or connector

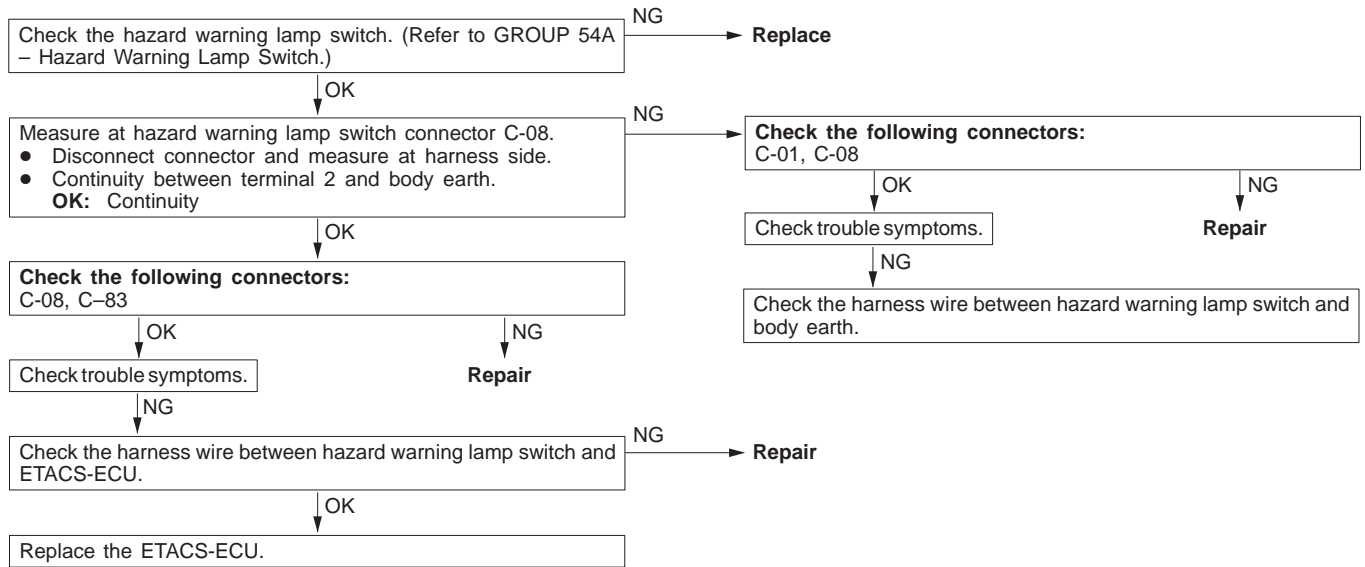

Inspection Procedure N-5

Front fog lamp switch signal is not sent to the ETACS-ECU.	Probable cause
The front fog lamp switch input signal is used to operate the front fog lamp. If the signal fails, front fog lamp will not work normally.	<ul style="list-style-type: none"> • Malfunction of fog lamp switch • Malfunction of ETACS-ECU • Malfunction of harness wire or connector

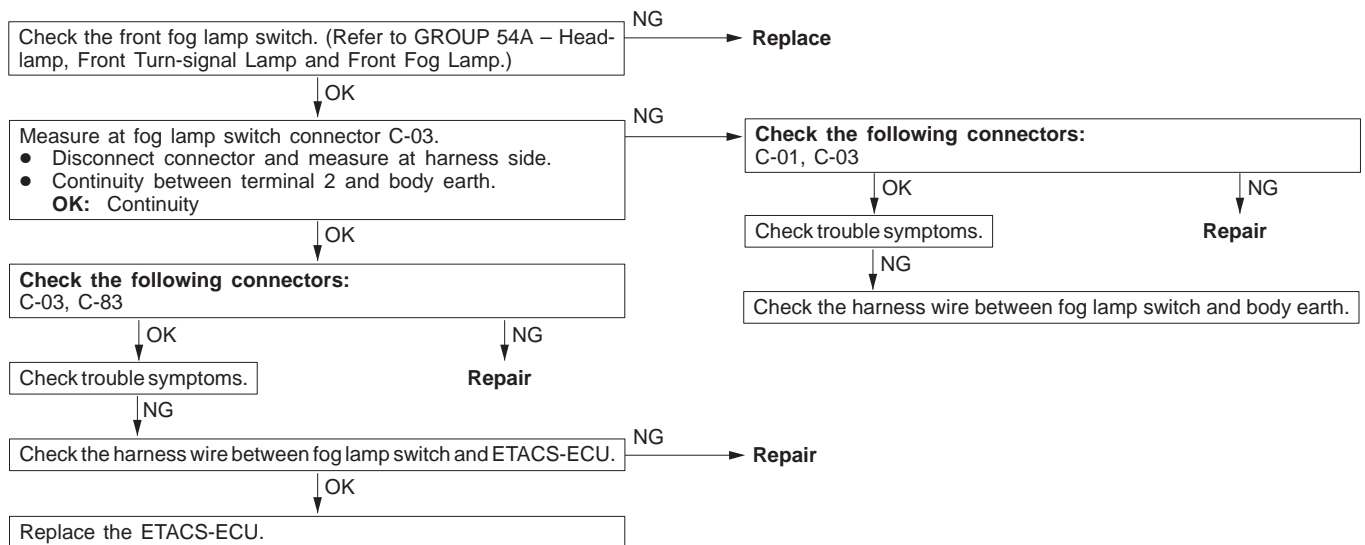

Inspection Procedure N-6

Rear fog lamp switch signal is not sent to the ETACS-ECU.	Probable cause
The rear fog lamp switch input signal is used to operate the rear fog lamp. If the signal fails, rear fog lamp will not work normally.	<ul style="list-style-type: none"> ● Malfunction of fog lamp switch ● Malfunction of ETACS-ECU ● Malfunction of harness wire or connector

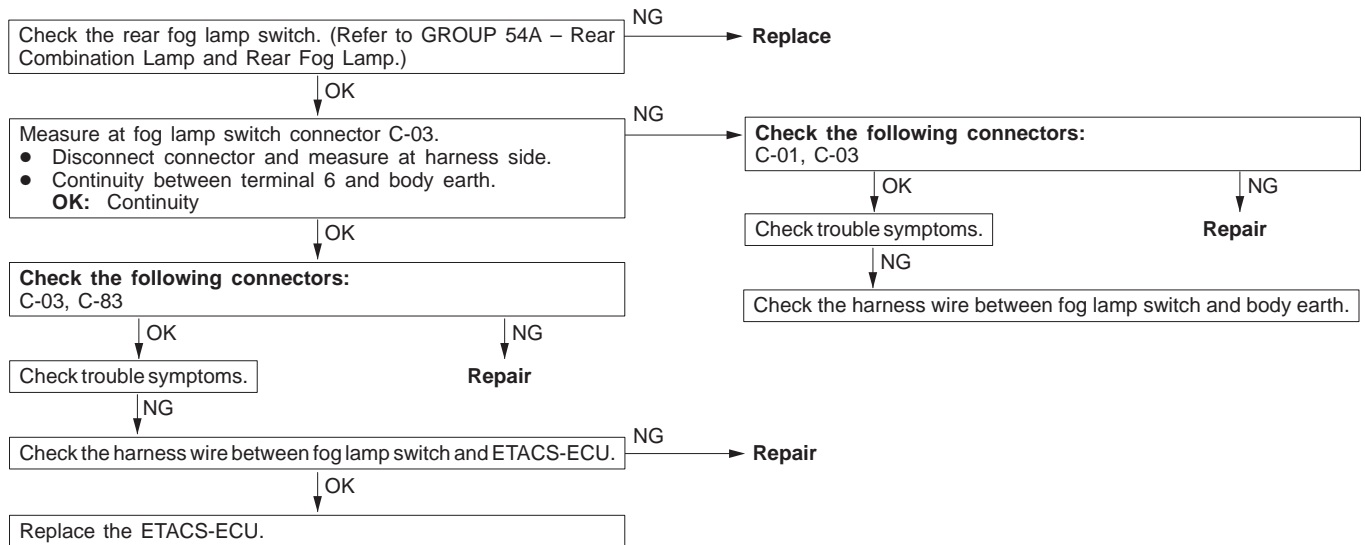

Inspection Procedure N-7

Back-up lamp switch signal is not sent to the ETACS-ECU. <M/T>	Probable cause
The back-up lamp switch input signal is used to operate the rear wiper. If the signal is an error, the rear wiper will not operate consecutively twice when the rear wiper is on and the shift lever is moved to R position.	<ul style="list-style-type: none"> ● Malfunction of back-up lamp switch ● Malfunction of ETACS-ECU ● Malfunction of harness wire or connector

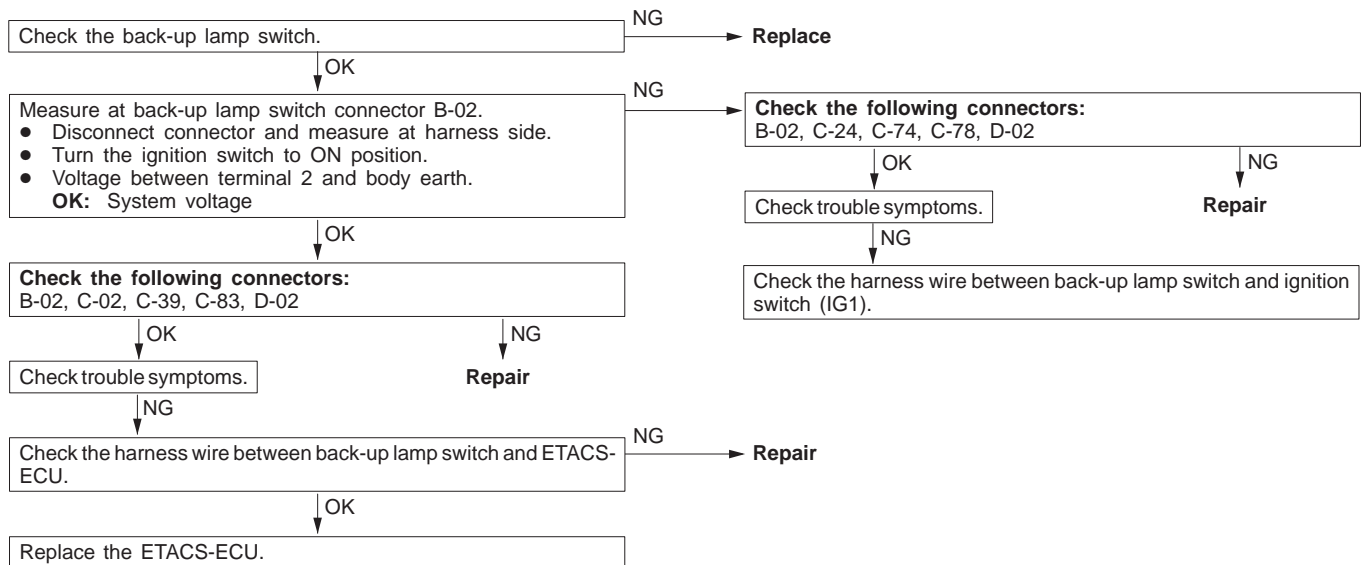

Inspection Procedure N-8

Inhibitor switch (reverse) signal is not sent to the ETACS-ECU. <A/T>	Probable cause
The inhibitor switch (reverse) input signal is used to operate the rear wiper. If the signal is an error, the rear wiper will not operate consecutively twice when the rear wiper is on and the selector lever is moved to R position.	<ul style="list-style-type: none"> ● Malfunction of inhibitor switch ● Malfunction of ETACS-ECU ● Malfunction of harness wire or connector

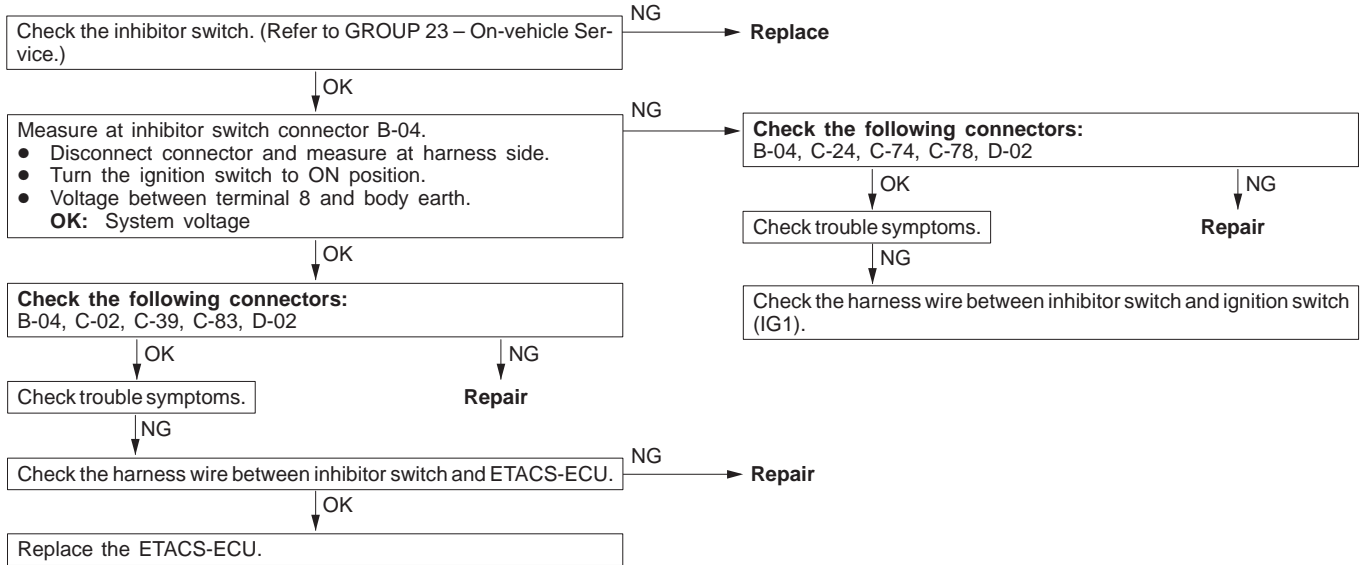

Inspection Procedure N-9

Rear wiper motor auto-stop signal is not sent to the ETACS-ECU.	Probable cause
Rear wiper motor auto-stop signal is used to operate the rear wiper. If the signal is an error, the rear wiper will not stop at the predetermined park position.	<ul style="list-style-type: none"> ● Malfunction of rear wiper motor ● Malfunction of ETACS-ECU ● Malfunction of harness wire or connector

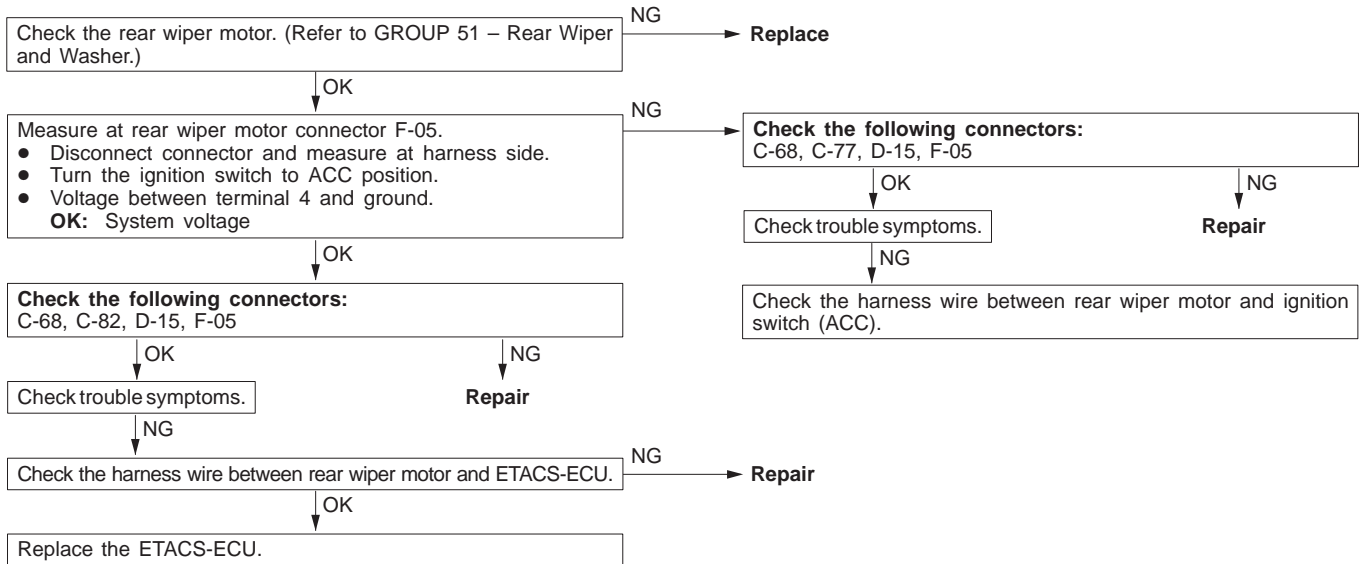

Inspection Procedure N-10

Driver's door switch signal is not sent to the ETACS-ECU.	Probable cause
<p>Door switches signal is not sent to the ETACS-ECU.</p>	
<p><Driver's door switch> The driver's door switch is used to operate the following functions. If the signal fails, these devices will not work normally.</p> <ul style="list-style-type: none"> • Light reminder warning function • Forgotten key prevention function <vehicles with keyless entry system> • Power window timer function <vehicles with power window> • Headlamp auto-cut function <p><Door switches> The door switches is used to operate the following devices. If the signal fails, these devices will not work normally.</p> <ul style="list-style-type: none"> • Keyless entry system <vehicles keyless entry system> • Room lamp dimming function 	<ul style="list-style-type: none"> • Malfunction of driver's or passenger's door switch • Malfunction of back door latch • Malfunction of ETACS-ECU • Malfunction of harness wire or connector

<Driver's and passenger's door switch>

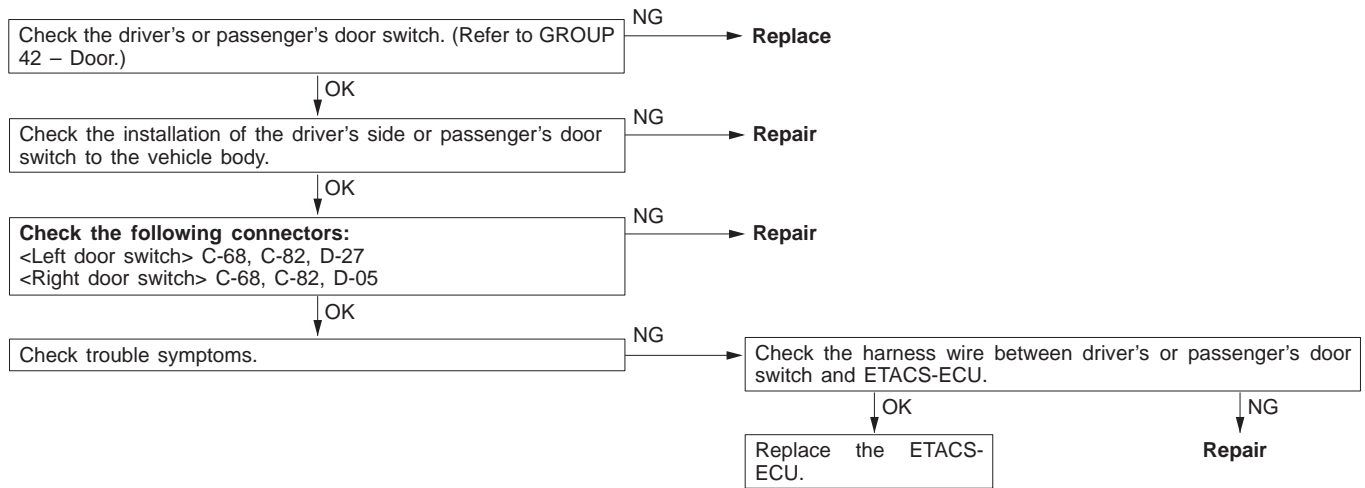

<Back door switch>

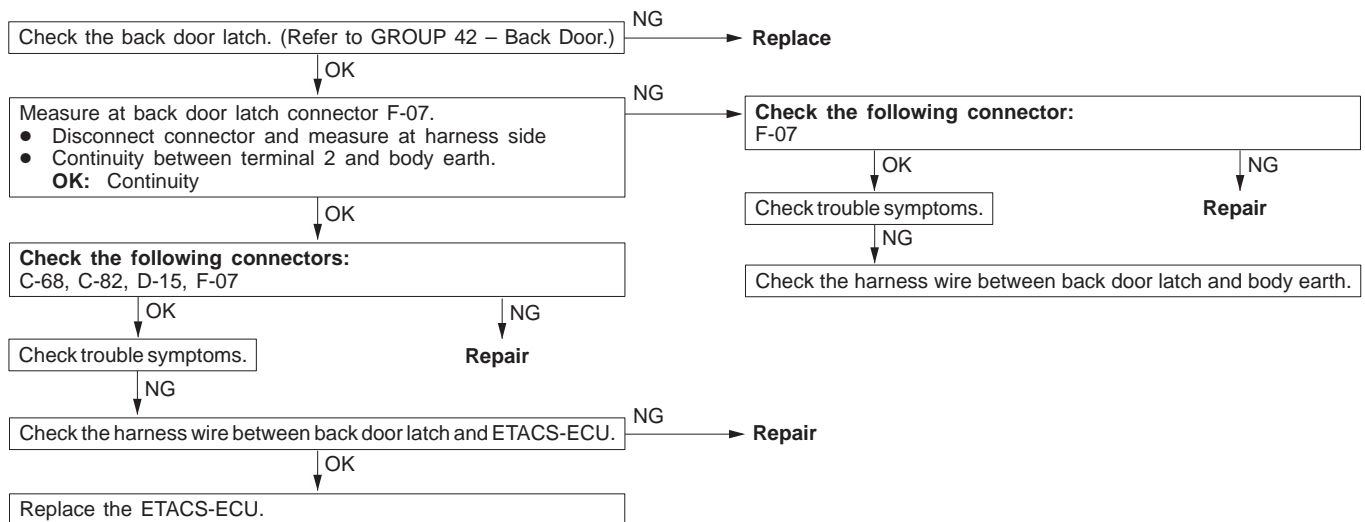

Inspection Procedure N-11

Passenger's door lock key cylinder switch signal is not sent to the ETACS-ECU.	Probable cause
<p>The passenger's door lock key cylinder switch is used to operate the central door locking system. If the signal fails, central door locking system will not work normally.</p>	<ul style="list-style-type: none"> ● Malfunction of passenger's door lock key cylinder switch ● Malfunction of ETACS-ECU ● Malfunction of harness wire or connector

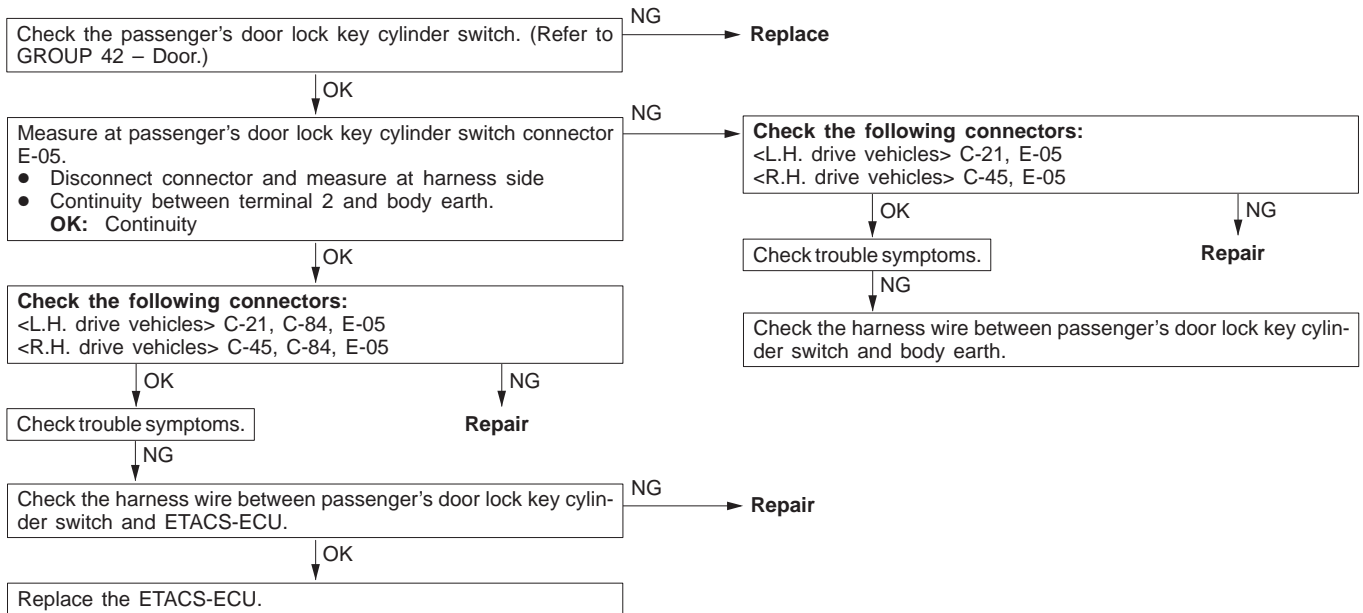

Inspection Procedure N-12

Back door lock key cylinder switch signal is not sent to the ETACS-ECU.	Probable cause
<p>The back door lock key cylinder switch is used to operate the central door locking system. If the signal fails, central door locking system will not work normally.</p>	<ul style="list-style-type: none"> ● Malfunction of back door lock key cylinder switch ● Malfunction of ETACS-ECU ● Malfunction of harness wire or connector

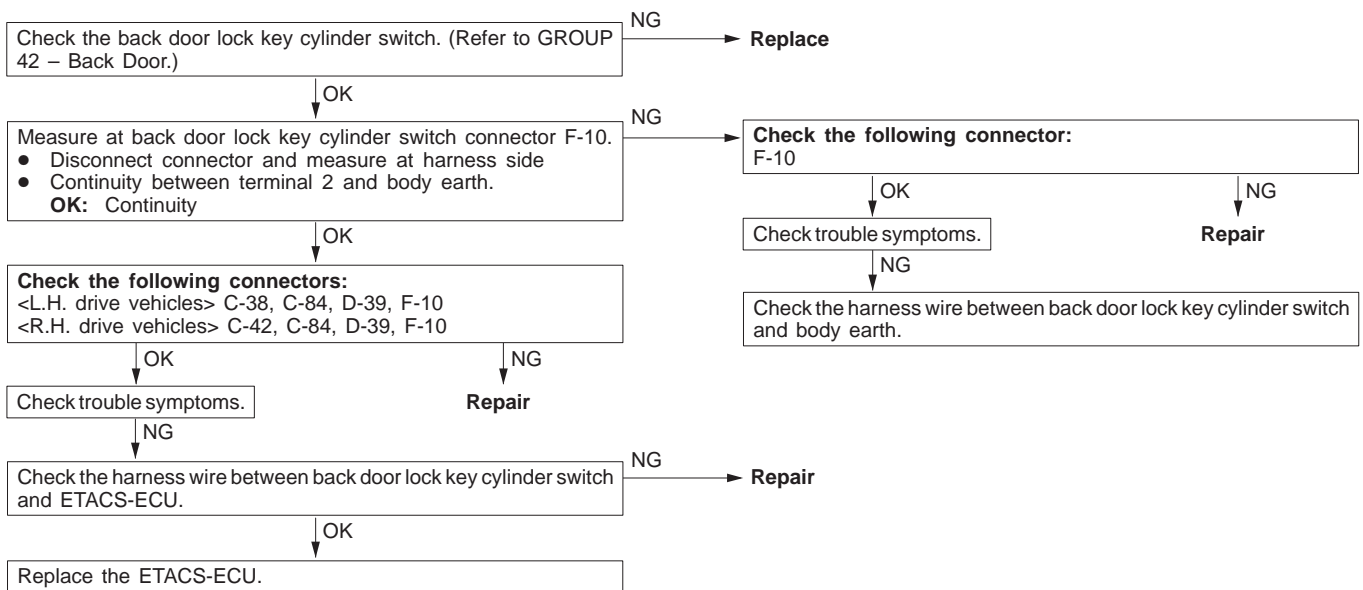

Inspection Procedure N-13

Driver's door lock actuator switch signal is not sent to the ETACS-ECU.	Probable cause
The driver's door lock actuator switch is used to operate the following systems or functions. If the signal fails, these systems or function will not work normally. <ul style="list-style-type: none"> ● Central door locking system ● Forgotten key prevention function <vehicles with keyless entry system> ● Keyless entry system <vehicles with keyless entry system> 	<ul style="list-style-type: none"> ● Malfunction of driver's door lock actuator ● Malfunction of ETACS-ECU ● Malfunction of harness wire or connector

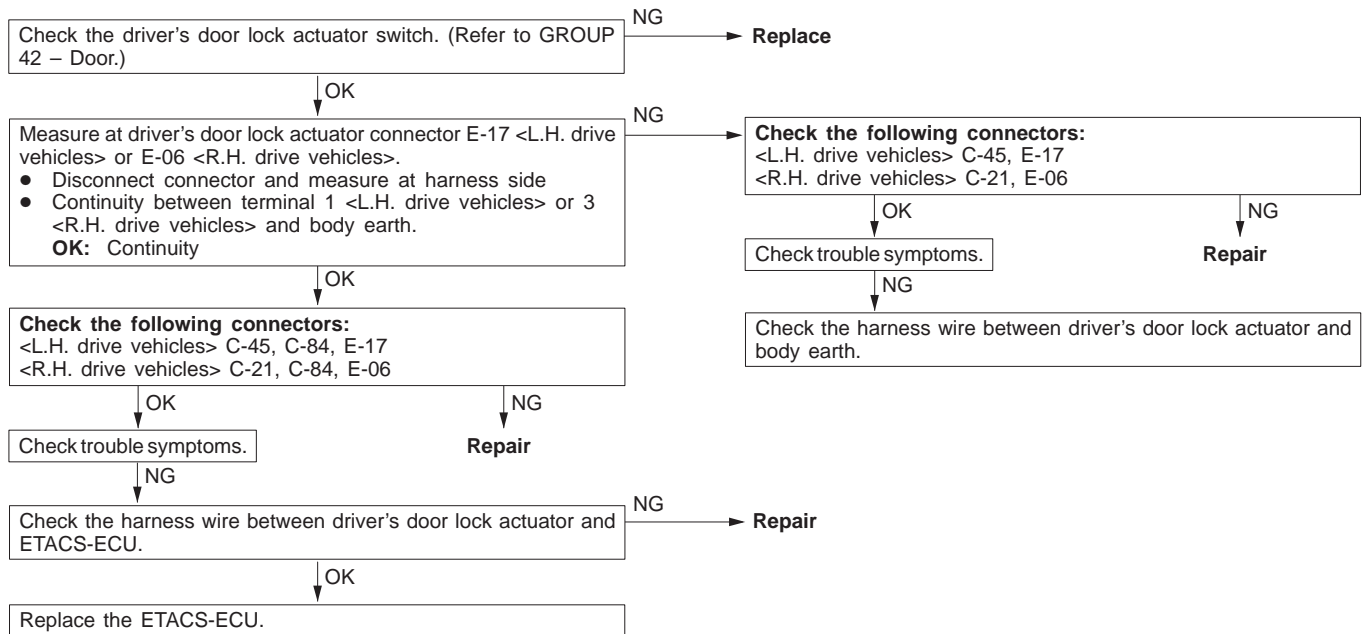

Inspection Procedure N-14

Column switch: <ul style="list-style-type: none"> ● Tail lamp switch signal is not sent to the ETACS-ECU. ● Headlamp switch signal is not sent to the ETACS-ECU. ● Dimmer switch signal is not sent to the ETACS-ECU. ● Passing switch signal is not sent to the ETACS-ECU. ● Turn-signal lamp switch signal is not sent to the ETACS-ECU. ● Windshield mist wiper switch signal is not sent to the ETACS-ECU. ● Windshield intermittent wiper switch signal is not sent to the ETACS-ECU. ● Windshield low-speed wiper switch signal is not sent to the ETACS-ECU. ● Windshield high-speed wiper switch signal is not sent to the ETACS-ECU. ● Windshield washer switch is not sent to the ETACS-ECU. ● Rear wiper switch is not sent to the ETACS-ECU. ● Rear washer is not sent to the ETACS-ECU. ● Headlamp washer switch is not sent to the ETACS-ECU. 	Probable cause
<p>The column switch is used to operate the following systems or functions. If the signal fails, these systems or function will not work normally.</p> <ul style="list-style-type: none"> ● Light reminder warning function ● Windshield wiper and washer ● Rear wiper and washer ● Headlamp washer <vehicles with headlamp washer> ● Headlamp, tail lamp ● Turn-signal lamp ● Front fog lamp <vehicles with front fog lamp> ● Rear fog lamp 	<ul style="list-style-type: none"> ● Malfunction of column switch ● Malfunction of ETACS-ECU

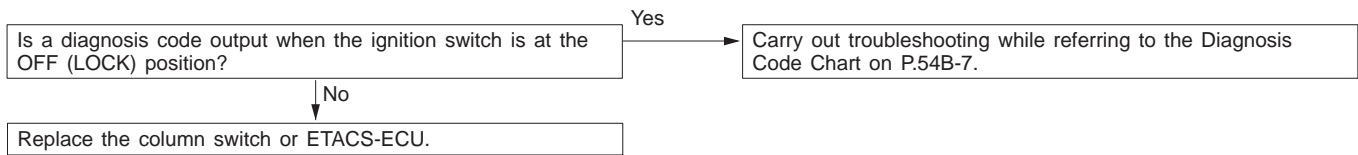

Inspection Procedure N-15

Column switch: Windshield intermittent wiper interval adjusting knob signal is not sent to the ETACS-ECU.	Probable cause
<p>If the windshield intermittent wiper interval adjusting knob is defective the windshield intermittent wiper interval can not be adjusted.</p>	<ul style="list-style-type: none"> ● Malfunction of column switch ● Malfunction of ETACS-ECU ● Malfunction of harness wire or connector

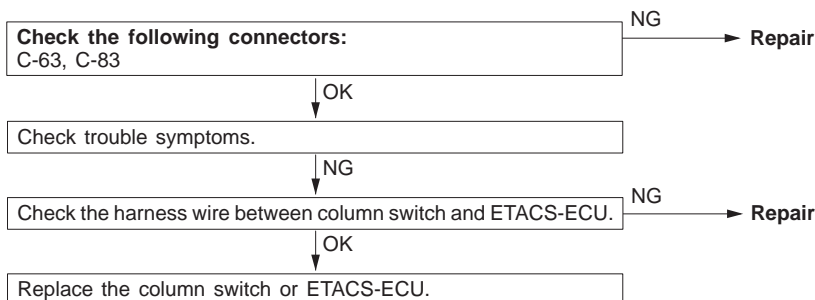

Inspection Procedure N-16

Power window main switch: Any switch signal is not sent to the ETACS-ECU.	Probable cause
If there is a problem with communication between the power window main switch and the ETACS-ECU, the input signal check for the power window main switch can no longer be carried out. In addition, the power window timer function will also stop working.	<ul style="list-style-type: none"> ● Malfunction of power window main switch ● Malfunction of ETACS-ECU ● Malfunction of harness wire or connector

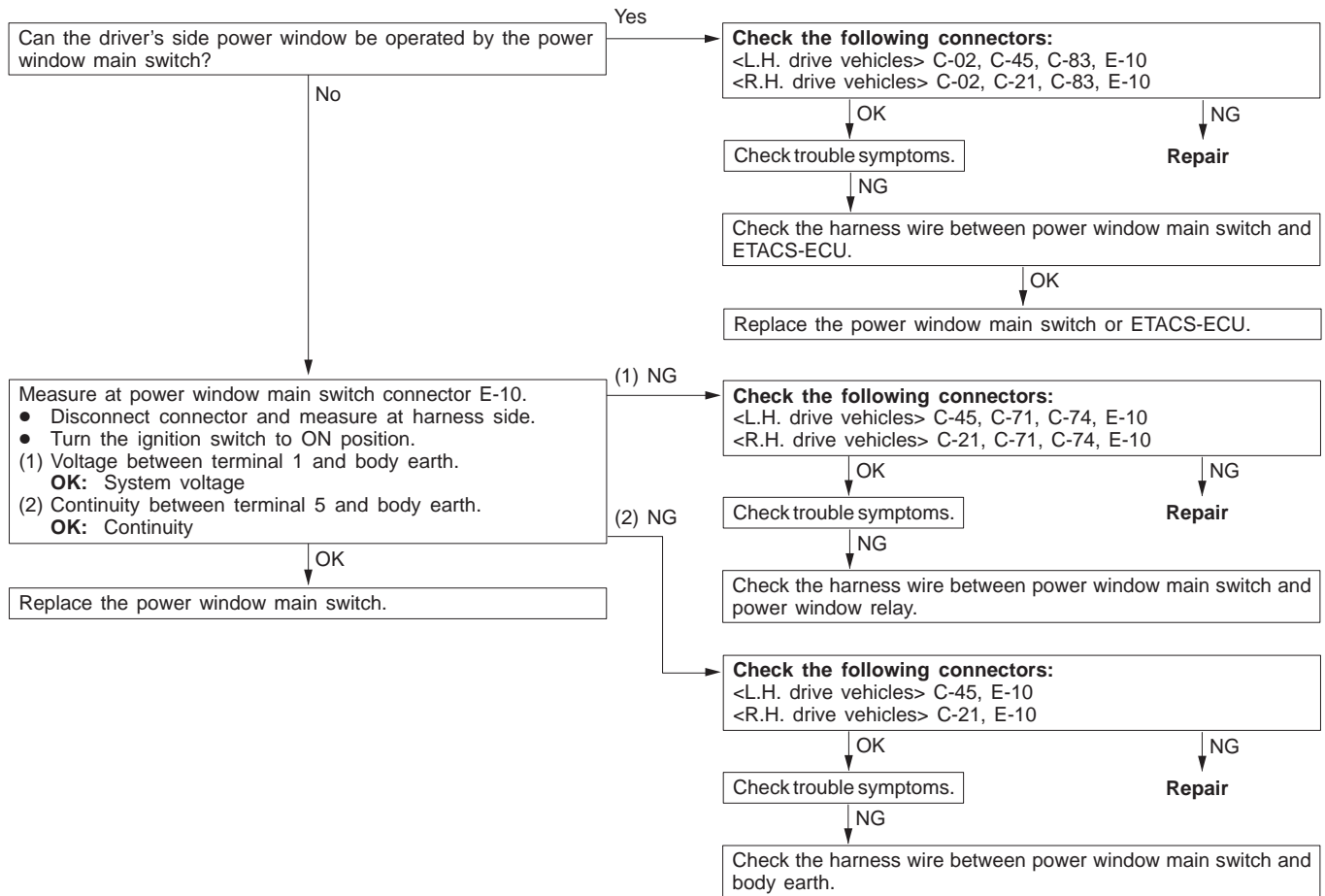

Inspection Procedure N-17

Transmitter: Any switch signal is not sent to the ETACS-ECU.	Probable cause
The transmitter input signal is used to operate the keyless entry system. If the signal fails, keyless entry will not work normally.	<ul style="list-style-type: none"> ● Malfunction of transmitter ● Malfunction of ETACS-ECU

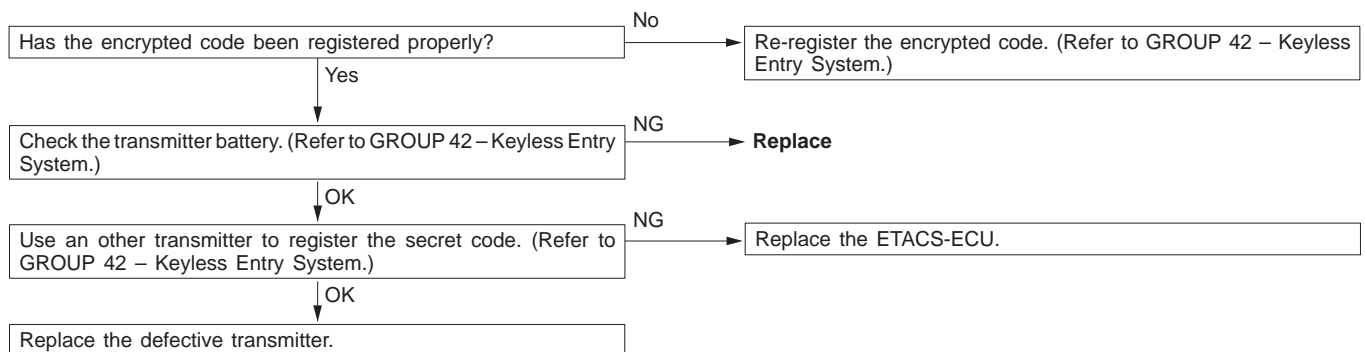

Inspection Procedure N-18

Multi-center display: Any switch signal is not sent to the ETACS-ECU.	Probable cause
The cause is probably a malfunction of the multi-center display or the ETACS-ECU.	<ul style="list-style-type: none"> ● Malfunction of multi-center display ● Malfunction of ETACS-ECU ● Malfunction of harness wire or connector.

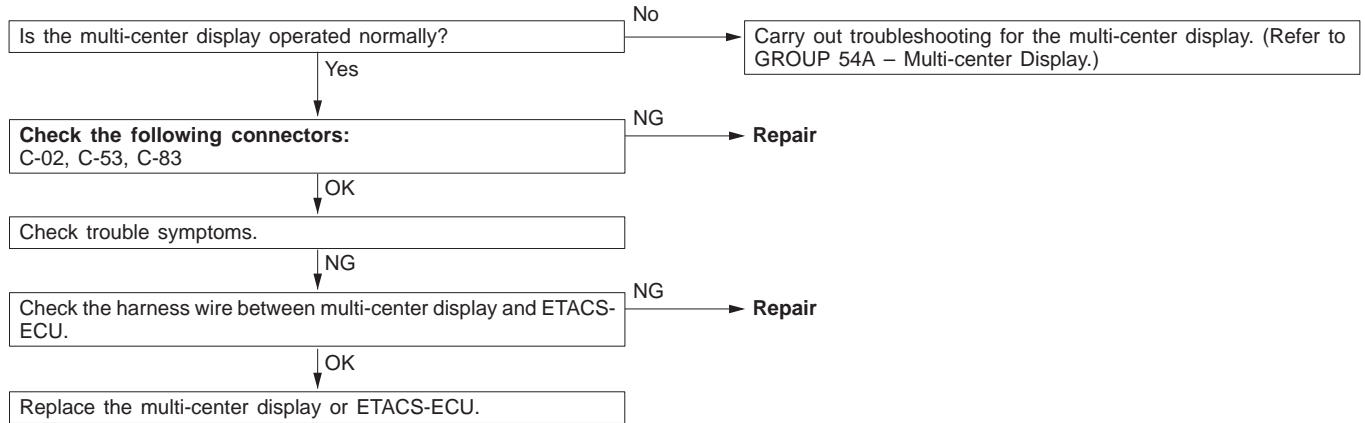

Inspection Procedure O-1

Check the circuit (power supply line) from the battery to the ETACS-ECU.	Probable cause
If that power supply circuit is defective, the circuit flowing through the ignition switch (IG1) will function as a back-up circuit. In this case, the following functions will not work when the ignition switch is at LOCK (OFF) position. <ul style="list-style-type: none"> ● Light reminder alarm function ● Central door lock ing system ● Hazard warning lamp ● Room lamp 	<ul style="list-style-type: none"> ● Malfunction of ETACS-ECU ● Malfunction of harness wire or connector.

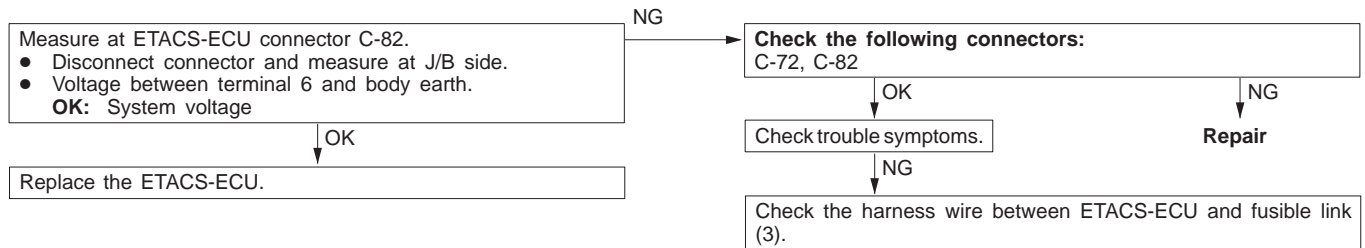

NOTES

GROUP 54B

SMART WIRING SYSTEM(SWS)

GENERAL

OUTLINE OF CHANGES

- Due to the introduction of 5-door models, the troubleshooting for the rear power windows have been added.

TROUBLESHOOTING

TROUBLE SYMPTOM CHART

Trouble symptom		Inspection procedure	Reference page
Power window	Rear power window sub-switches can not operate rear door windows. (However, power window main switch can operate rear door windows.)	D-9	54B-2

Inspection Procedure D-9

<p>Power windows: Rear power window sub-switches can not operate rear door windows. (However, power window main switch can operate rear door windows.)</p>	<p>Probable cause</p>
<p>Power supply circuit or earth circuit of the rear power window motor, rear power window motor or rear power window sub-switches may be defective.</p>	<ul style="list-style-type: none"> ● Malfunction of rear power window sub-switches ● Malfunction of rear power window motors ● Malfunction of wiring harness or connector

